

Hitachi Power Tools

PNEUMATIC TOOL PARTS LIST

■ PIN NAILER
Model NP 35A

2014 • 09 • 09
(E2)

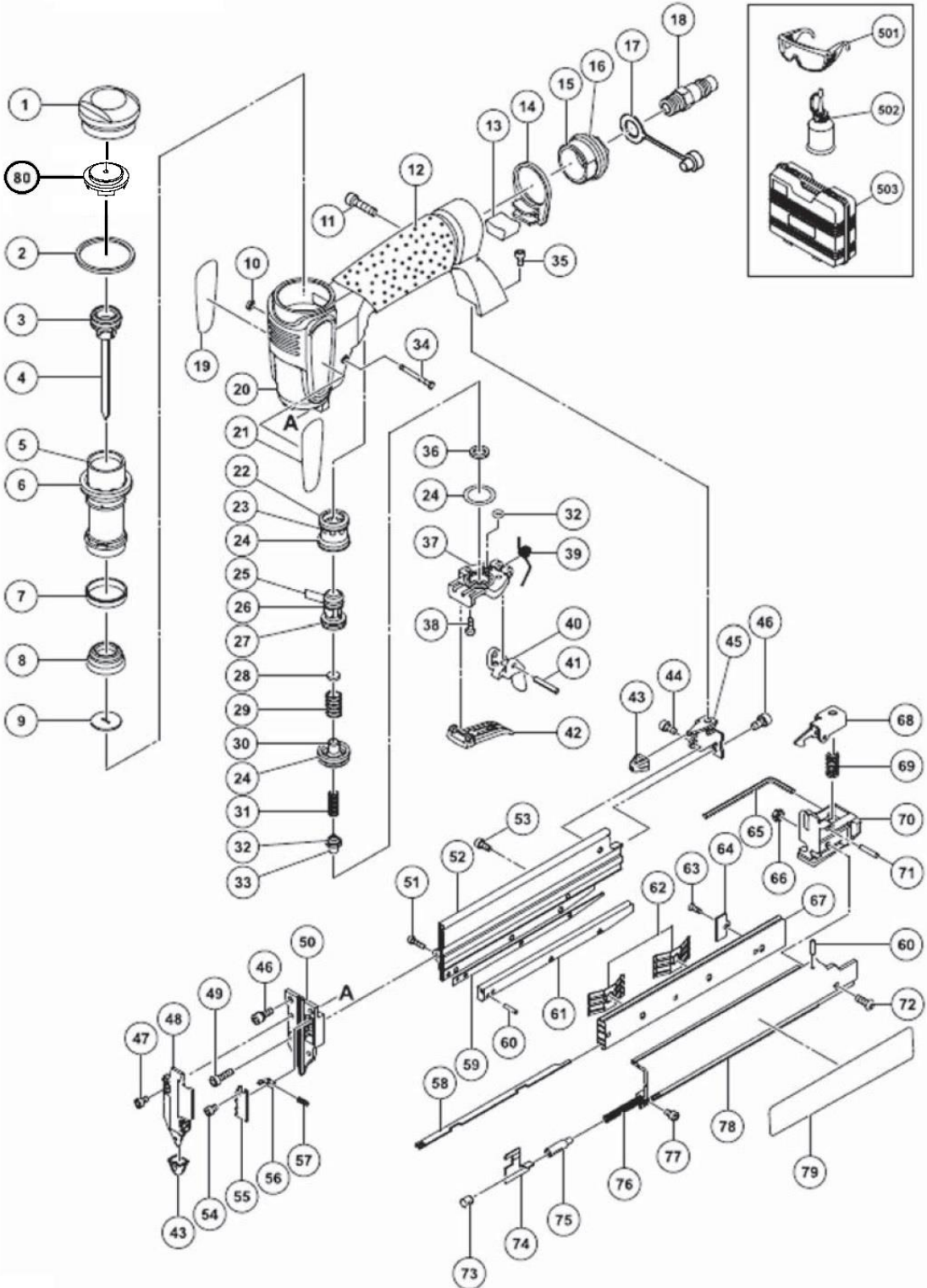

PARTS

NP35A

ITEM NO.	CODE NO.	DESCRIPTION	NO. USED	REMARKS
1	887556	HEAD COVER	1	
2	884641	PACKING	1	
3	884642	O - RING	1	
4	884643	DRIVER UNIT	1	
5	884644	CYLINDER	1	
6	884645	O - RING	1	
7	884646	CYLINDER RING	1	
8	884647	BUMPER	1	
9	884648	DRIVER GUIDE	1	
10	887654	RETANING RING	1	
11	887565	HEX.SOC.HD.BOLT M5x20	1	
12		RUBBER GRIP	1	Included in No. 20
13	884650	MUFFLER	1	
14	884651	GUIDE PLATE	1	
15	887562	END CAP	1	
16	884653	O - RING	1	
17	887563	DUST CAP	1	
18	887564	AIR PLUG	1	
19	887655	Hitachi Label (B)	1	
20	887561	BODY ASS'Y	1	Includes No. 12
21	877656	Hitachi Label (A)	1	
22	887558	O - RING	1	
23	884656	TRIGGER VALVE HEAD	1	
24	884657	O - RING	1	
25	884658	O - RING	1	
26	884659	VALVE PLUNGER	1	
27	884660	O - RING	1	
28	884661	CUSHIONS	1	
29	884662	SPRING	1	
30	884663	PLUNGER CAP	1	
31	884664	SPRING	1	
32	884665	O - RING	2	
33	884666	PLUNGER	1	
34	884655	TRIGGER PIVOT PIN	1	
35	887571	SEAL LOCK HEX.SOC.HD. BOLT M4x8	1	
36	884667	COLLAR	1	
37	884669	VALVE COVER	1	
38	887559	HEX.SOC.HD.BOLT	2	
39	884668	LOCK SPRING	1	
40	884670	LOCK LEVER	1	
41	887560	ROLL PIN D3X18	1	
42	884671	TRIGGER	1	
43	884681	NOSE CAP(A)	2	
44	887569	HEX.SOC.HD.BOLT (W/SP.WASHER) M4x8	1	
45	884682	BRACKET UNIT	1	
46	884676	BOLT(W/WASHER)M4x12	3	
47	887570	HEX.SOC.HD.BOLT M4x6	2	
48	884673	NOSE	1	
49	884675	SEAL LOCK HEX.SOC.HD. BOLT M4x14	1	
50	884677	BLADE GUIDE	1	
51	884678	SEAL LOCK HEX.SOC.HD. BOLT M3x10	3	
52	884679	MAGAZINE A	1	
53	884680	SCREW M4	1	
54	884674	HEX.SOC.HD.BOLT M3x4	1	
55	884683	STOPPER	1	
56	884685	GUIDE LOCATOR	4	
57	884684	GUIDE LOCATING SPRING	4	
58	884686	SPACER	4	
59	884687	FLAT BAR	1	
60	887566	ROLL PIN D2X10	2	

