

HITACHI

Instruction Manual
Manual de instrucciones



UNIVERSAL WORKSTATION

UU610

Estación de trabajo universal
UU610

HITACHI

Customer Service 508-677-4130

Specifications:

Tool weight: 40 lbs.
Beam supports up to 500 lbs.
Supports 20 ft. material

Especificaciones:

Peso ligero de sólo 40 lbs.
La viga soporta hasta 500 lbs.
Soporta material de 20 pies.

Estimated assembly 30 minutes
Tiempo aproximado de ensamblado: 30 minutos

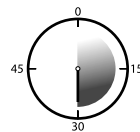

Customer Service 508-677-4130

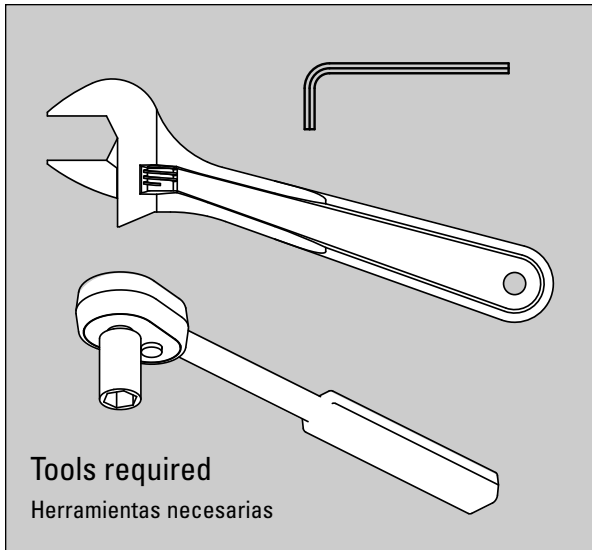

Tools required
Herramientas necesarias

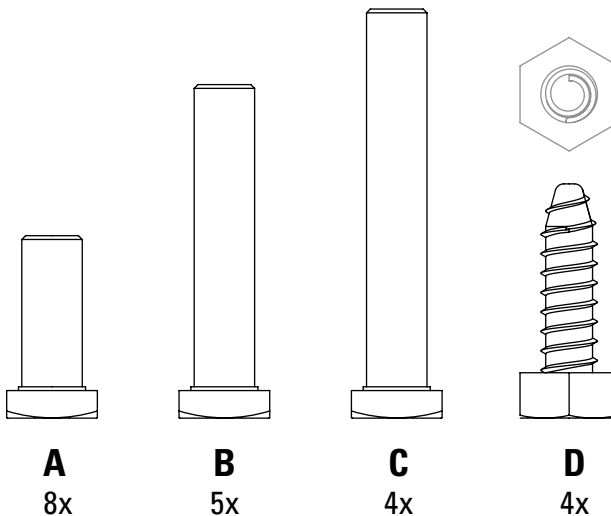

A
8x

B
5x

C
4x

D
4x

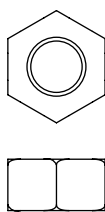

E
4x



F
8x

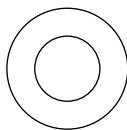

G
12x



H
4x

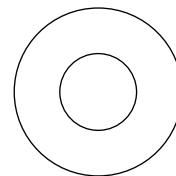

I
2x



J
4x

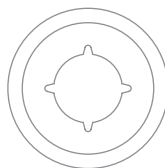

K
4x

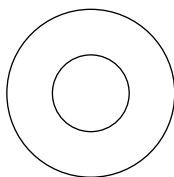

L
2x



M
2x

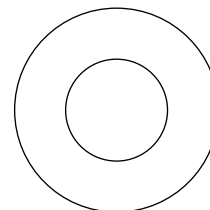
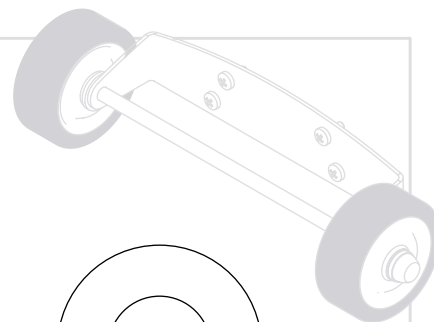

N
2x

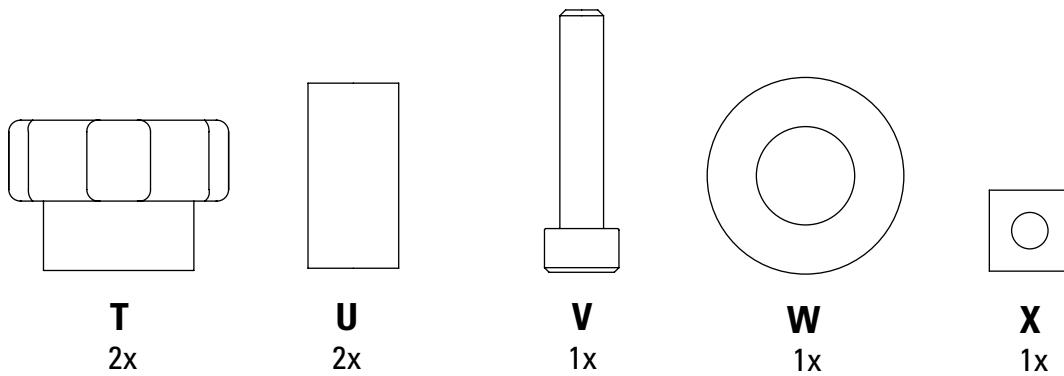
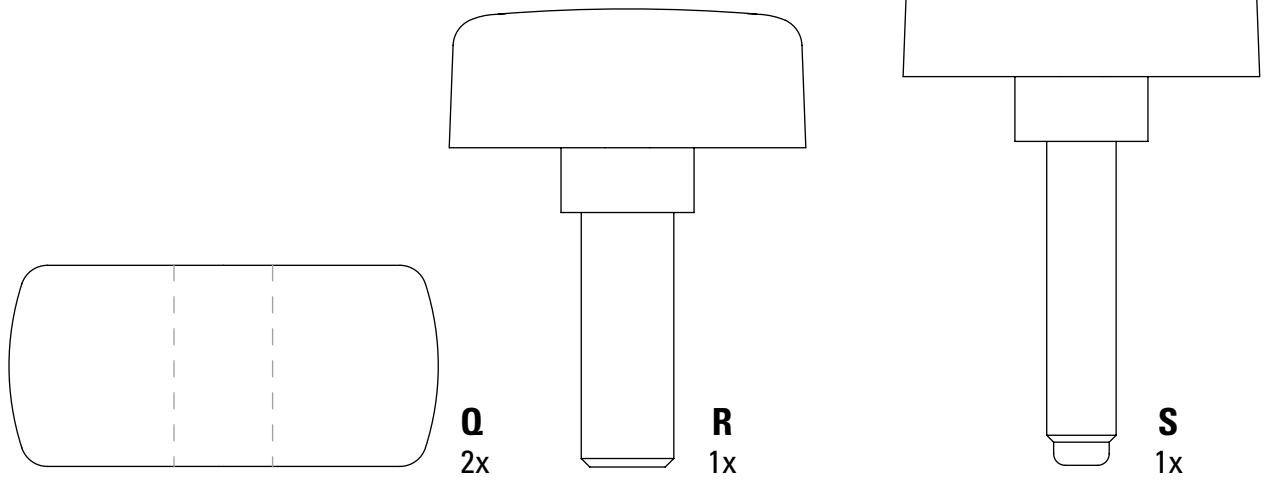
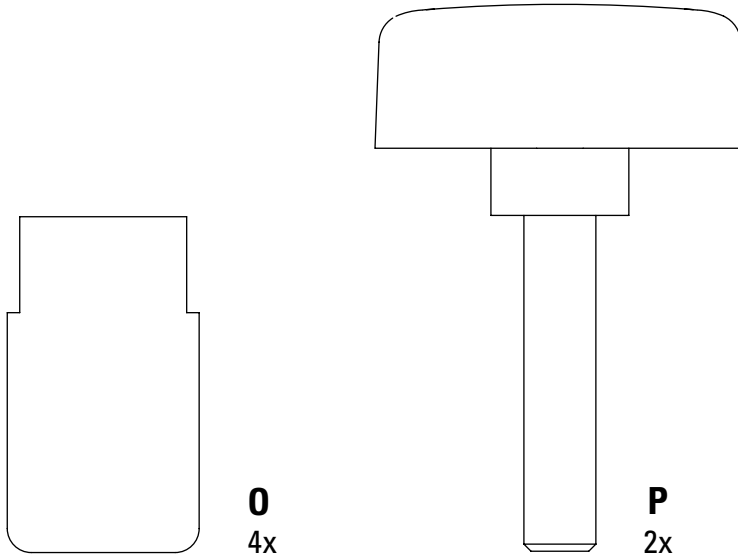

HITACHI

UU610 UNIVERSAL WORKSTATION

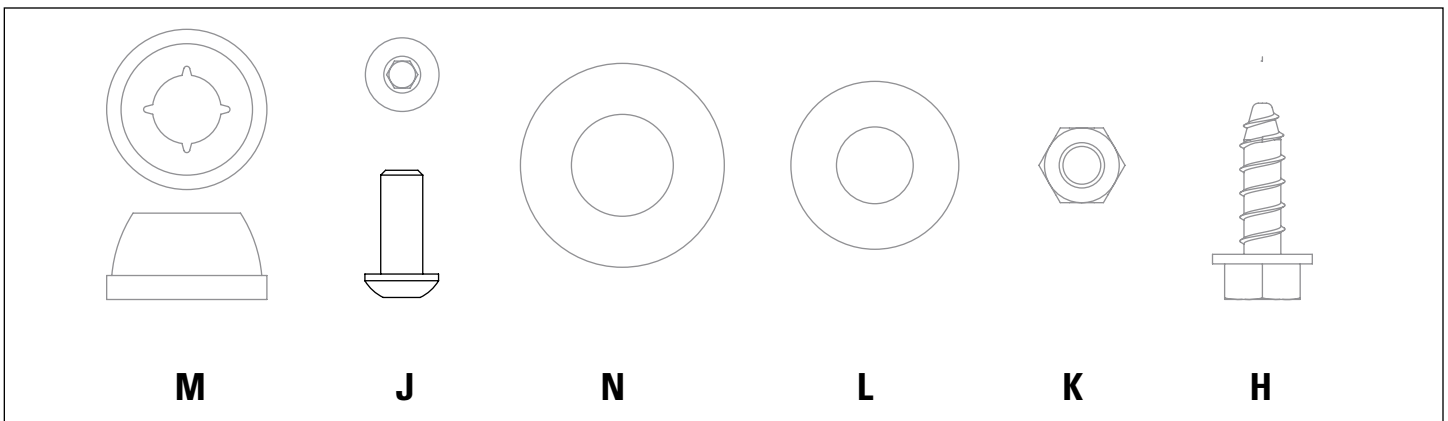
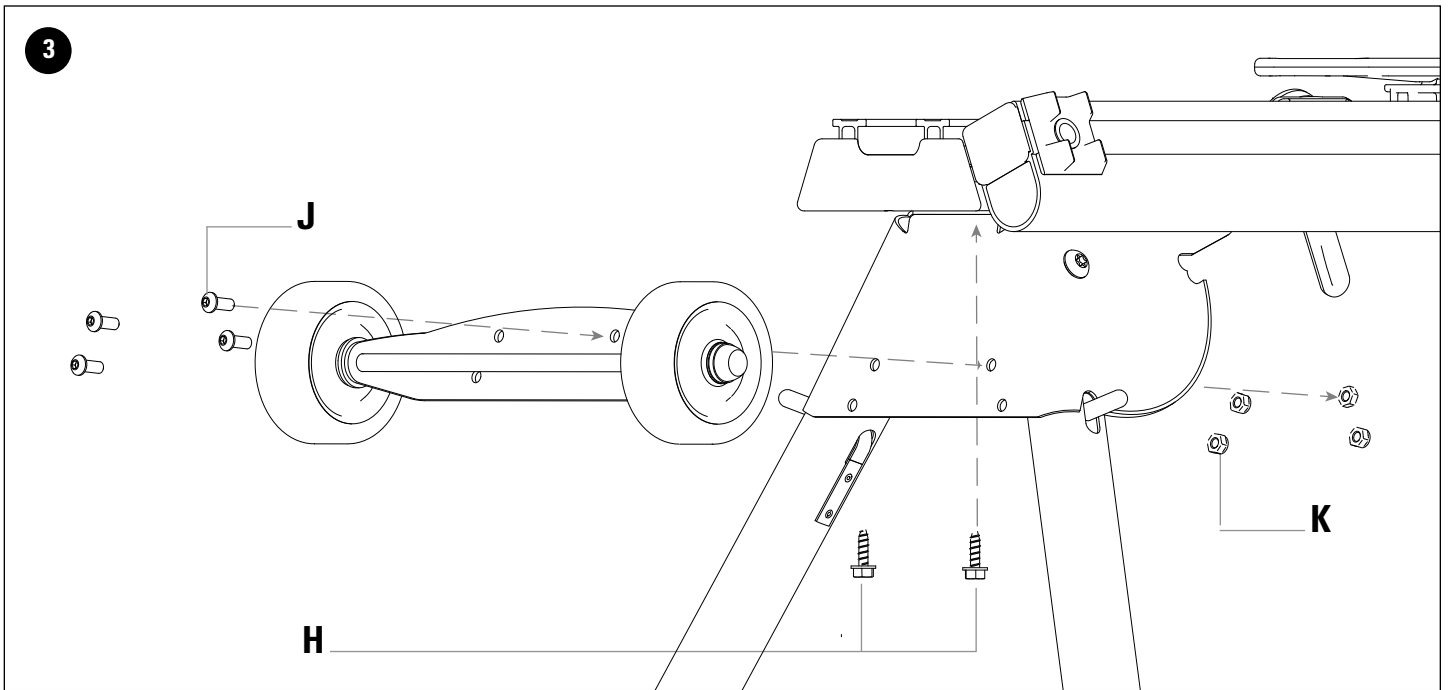
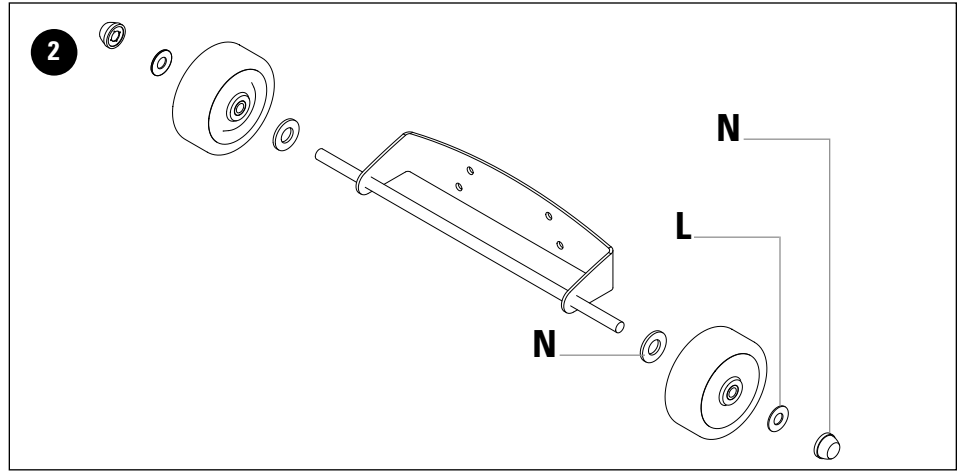
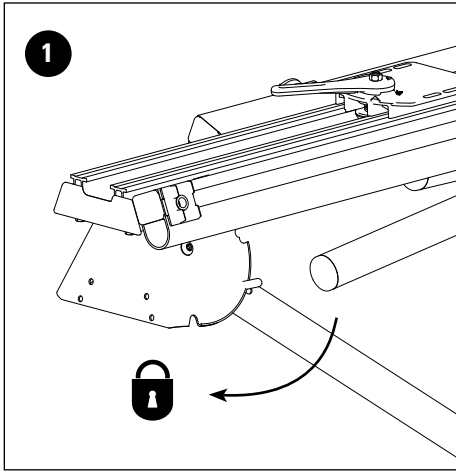

4

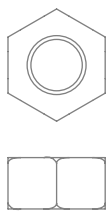
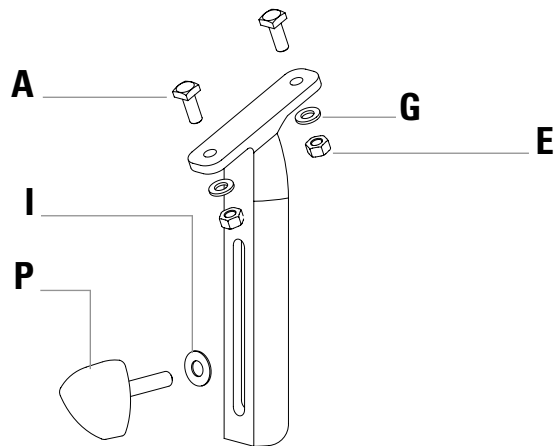
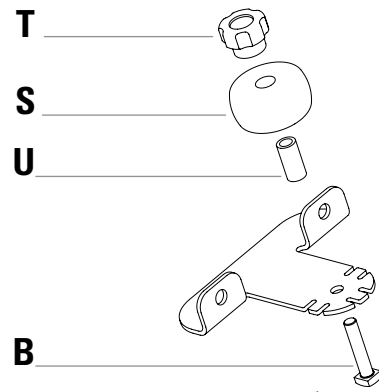
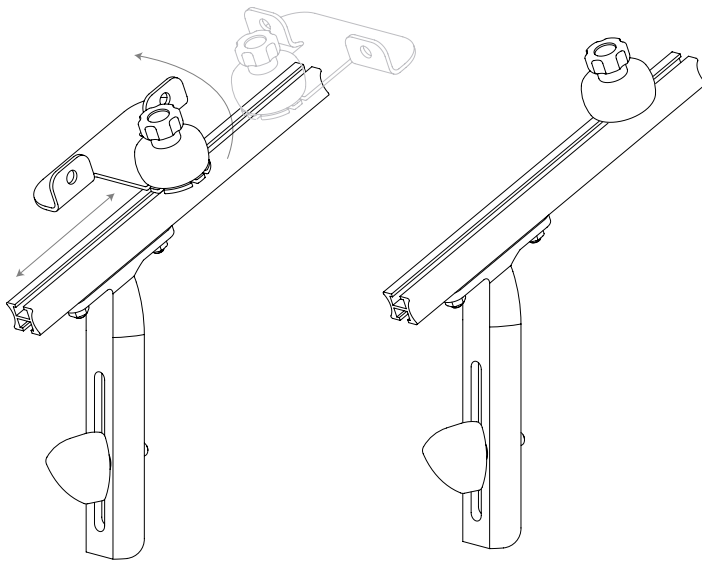

E A

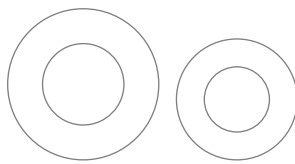

I G

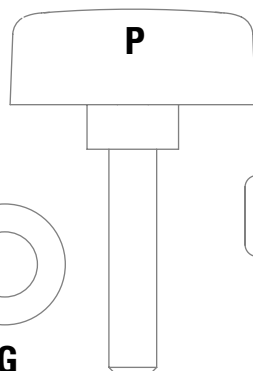

P

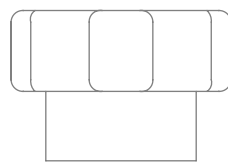

T



U

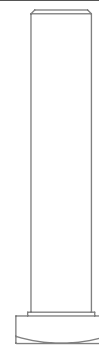

B

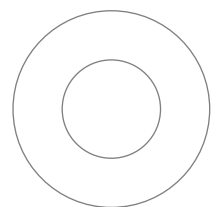

G

HITACHI

UU610 UNIVERSAL WORKSTATION

5

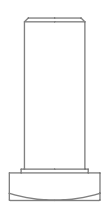
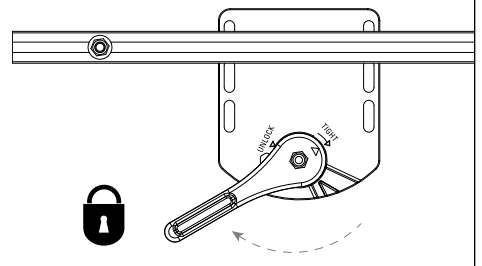
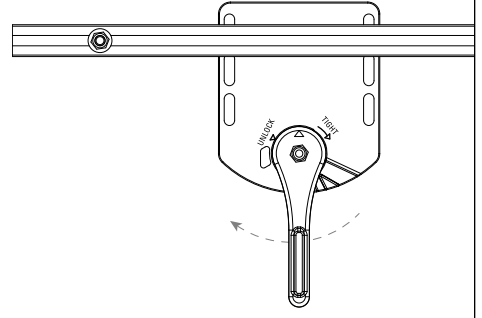
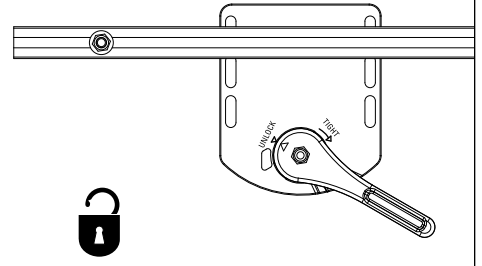
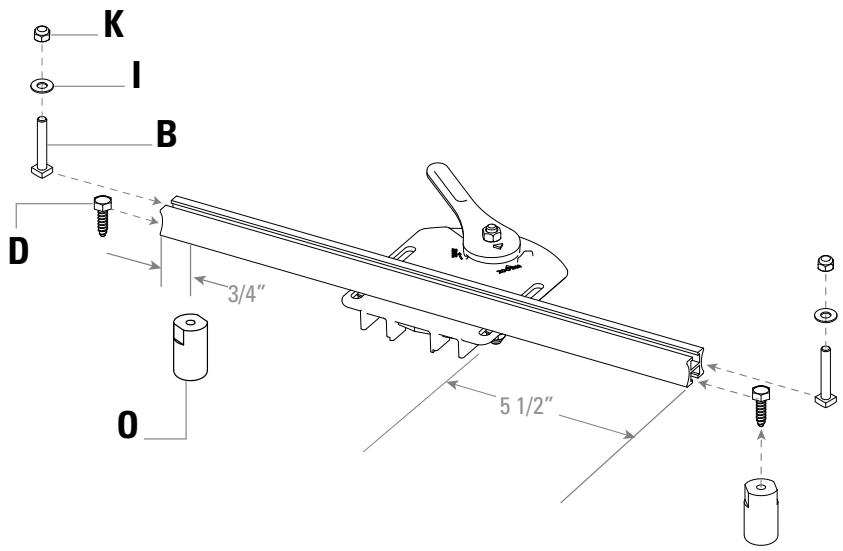
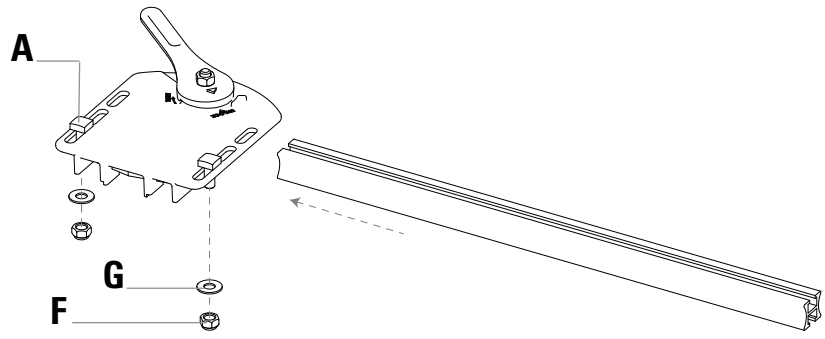

A

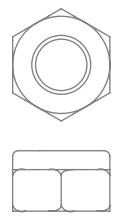

F

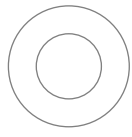

G

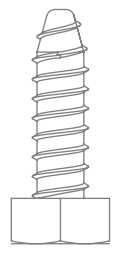

D

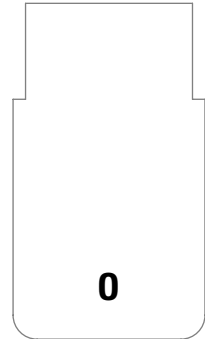

O

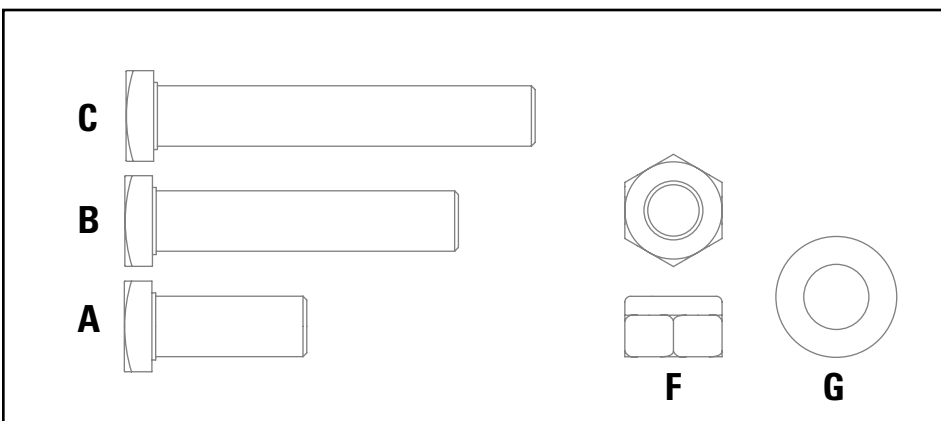
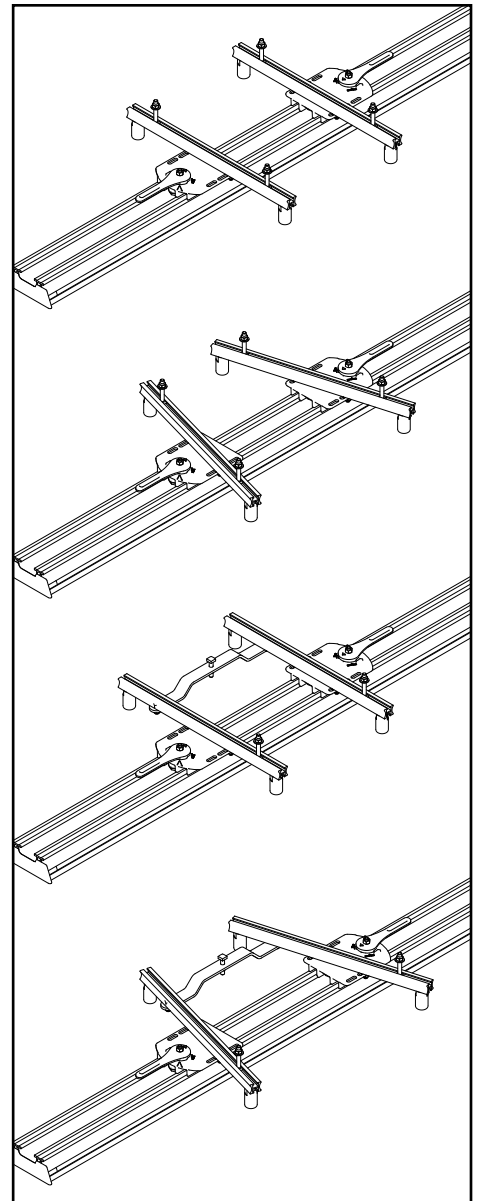
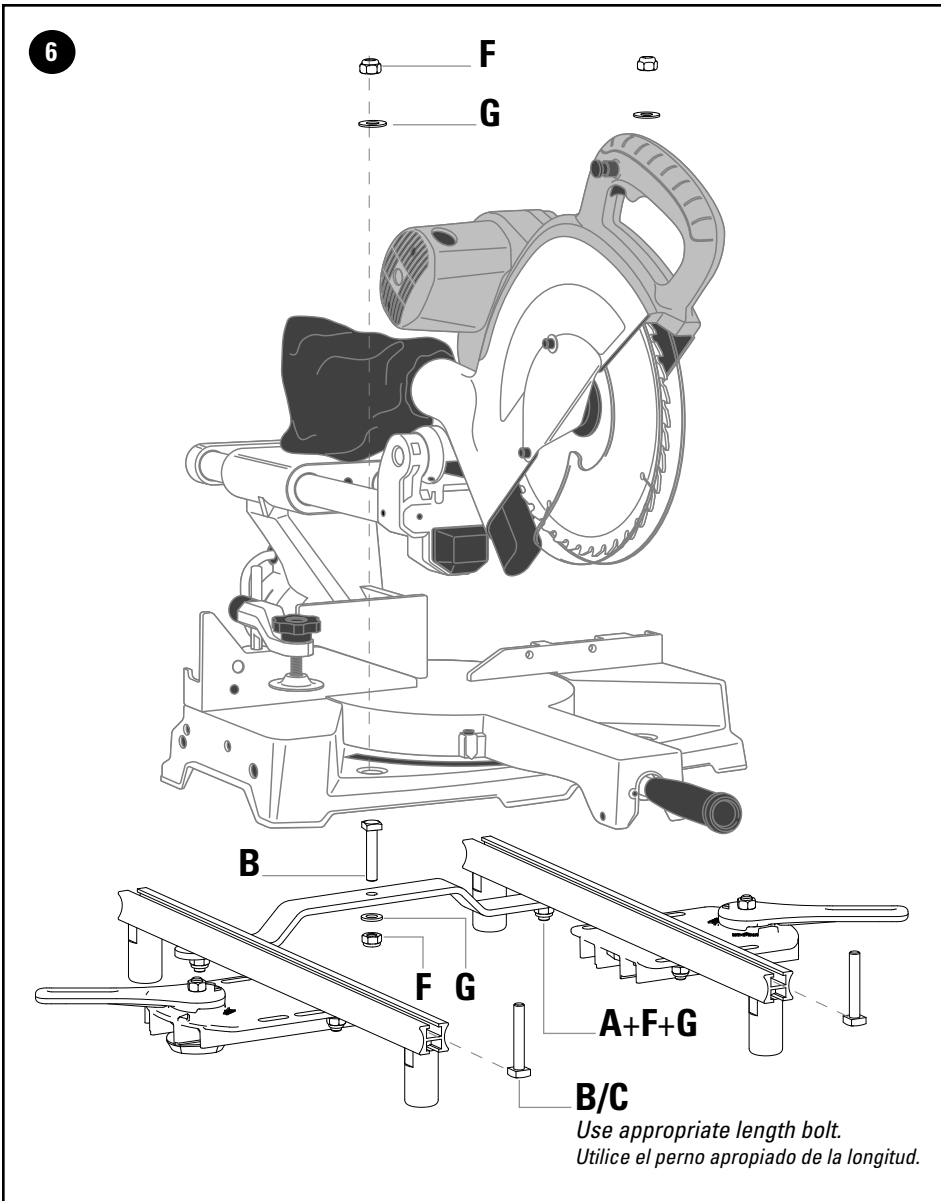

HITACHI

UU610 UNIVERSAL WORKSTATION

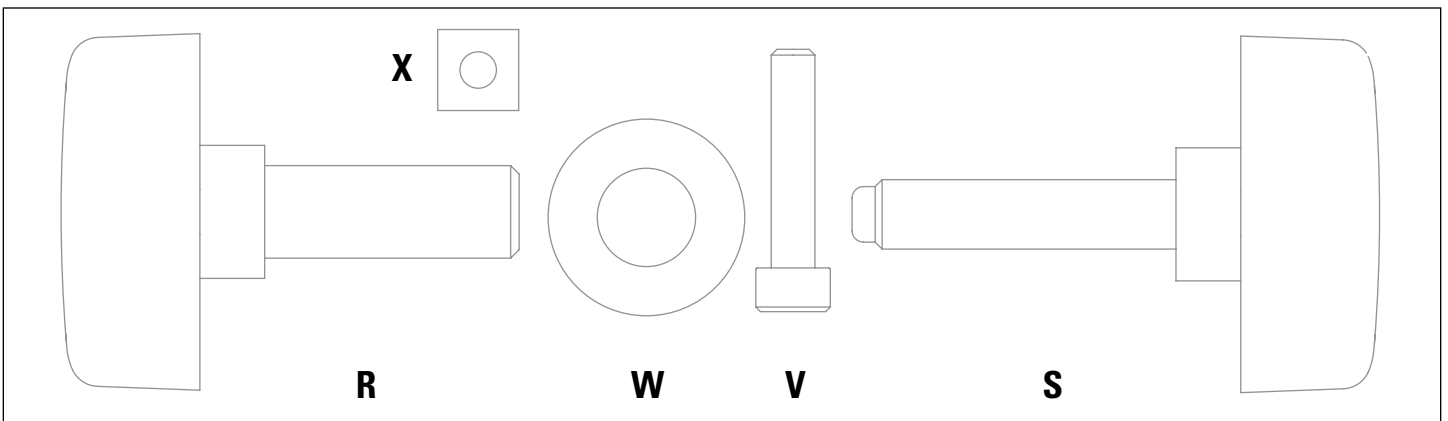
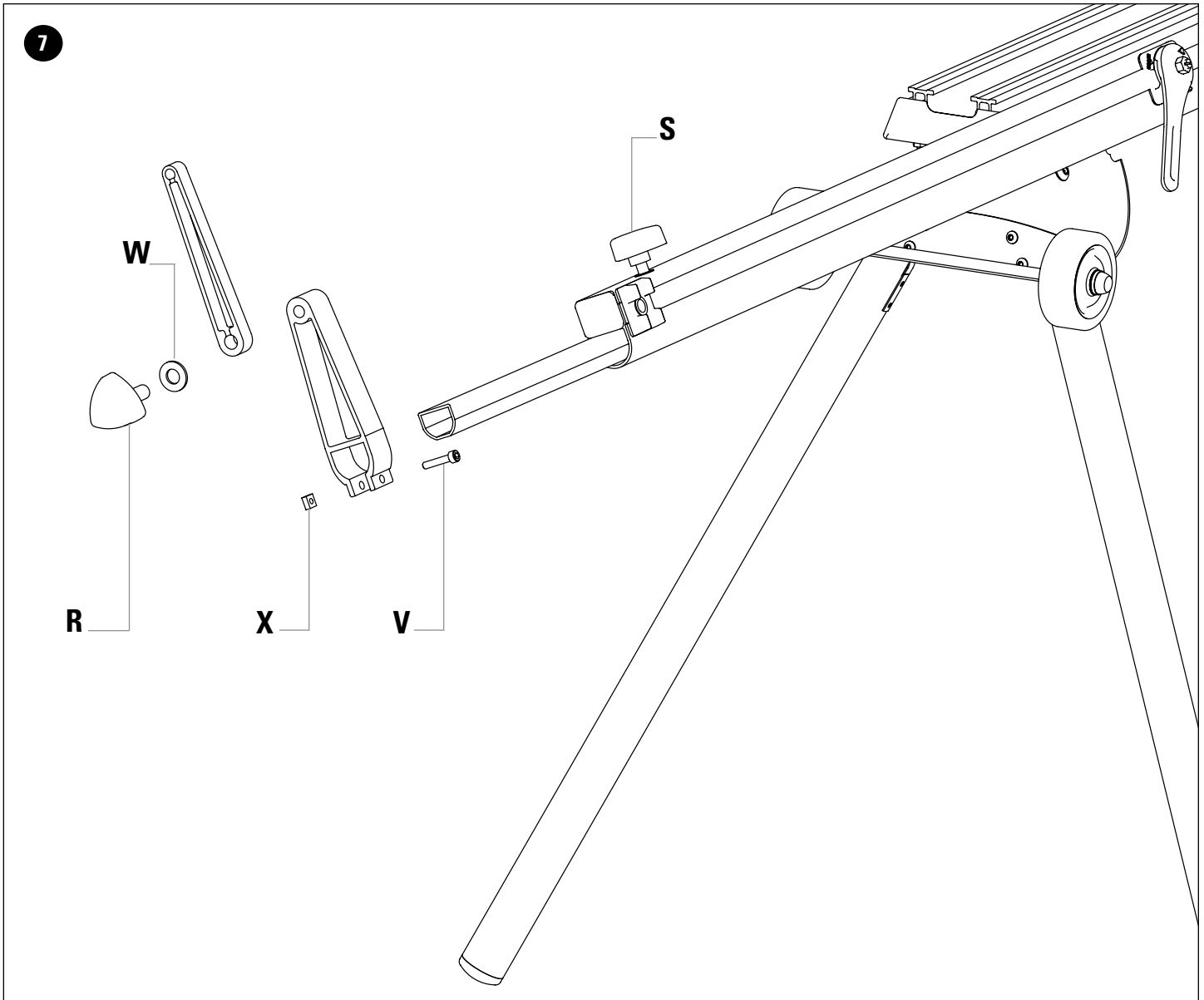

	PART NO.	ITEM	HITACHI P/N.	DESCRIPTION	QTY
BASERAIL and LEGS	AX-11096-1		726221	BASERAIL	1
	AX-14403-5		726222	ALUMINUM LEG	4
	01-25517		726223	LEG BRACKET	2
	PI-11005		726224	BASERAIL ENDCAP	2
	RI-14208		726225	FOOT ENDCAP	4
	SP-14201		726226	SPRING LOCK	4
	HD-80021		726227	3/8-16 SELF LOCKING HEX NUT	4
	HD-80033		726228	3/8-16 x 2.38 BUTTON SOCKET SCREW	4
	HD-80034		726229	1/4 x 5/8 RIVET	8
	HD-80035		726230	1/8 x 3/8 RIVET	8
	HD-80210	H	726231	ST6.3 x 20mm SELF TAPPING SCREW, WASHER HEX HEAD	4
WHEEL BRACKET	01-25518		726232	WHEEL BRACKET	1
	HD-80078	O	726233	3/8 WASHER	2
	HD-80150		726234	WHEEL WITH BUSHING	2
	HD-80153	M	726235	PUSH CAP	2
	HD-80154	N	726236	1/2 WASHER	2
	HD-80155		726237	3/8 ROD	1
	HD-80204	K	726238	M6-1.0 SELF LOCKING HEX NUT	4
	HD-80217	J	726239	SCREW, PAN HEAD M6-1.0 x 16mm	4
	TOOL MOUNT	ZN-11501		726240	TOOLMOUNT BRACKET
ZN-11099			726241	TOOLMOUNT RETAINER	2
ZN-11504			726242	CLAMP HANDLE METRIC	2
AX-11101			726243	KEY	2
AX-11102-2			726206	SUPPORT BEAM 18"	2
01-25512			726244	SAW ADAPTER PLATE	1
PI-11008		O	726245	TOOLMOUNT FOOT	4
SP-14202			726246	CONICAL SPRING	2
HD-80199-1			726247	M8-1.25 x 50mm HEX BOLT	2
HD-80200-1		A	726248	M8-1.25 x 20mm SQUARE HEAD BOLT	6
HD-80200-2		B	726249	M8-1.25 x 40mm SQUARE HEAD BOLT	3
HD-80200-3		C	726250	M8-1.25 x 50mm SQUARE HEAD BOLT	4
HD-80205		F	726251	M8-1.25 SELF LOCKING HEX NUT	11
HD-80206		E	726252	M8-1.25 HEX NUT	2
HD-80211		D	726253	ST8 x 25mm SELF TAPPING SCREW, HEX HEAD	4
HD-80214		G	726254	M8 WASHER	13

HITACHI

UU610 UNIVERSAL WORKSTATION

	PART NO.	ITEM	HITACHI P/N.	DESCRIPTION	QTY
SUPPORT ARM	01-25511		726255	BENT STOP	1
	AX-11097-3		726256	SUPPORT ARM	2
	AX-11102-1		726257	SUPPORT BEAM 12"	2
	AX-11111	U	726258	BUSHING	2
	ZN-11504		726259	CLAMP HANDLE METRIC	2
	ZN-11108		726260	CLAMP BASE	2
	ZN-11500		726261	SUPPORT ADAPTER	2
	ZN-11503		726262	WORK SUPPORT BRACKET	2
	KB-90021	P	726263	KNOB, 3/8-16	2
	KB-90028	T	726264	KNOB, M8-1.25	2
	PI-11004		726265	SLIDE PAD	4
	PI-11007		726286	ENDCAP	4
	HD-11109		726267	SLIDER BOLT PAD	2
	HD-12021		726268	3/8-16 RIVNUT	2
	HD-80034		726269	1/4 x 5/8 RIVET	8
	HD-80078	T	726270	3/8 WASHER	2
	HD-80192		726271	1/8 x 5/8 RIVET	2
	HD-80200-1	A	726272	M8-1.25 x 20mm SQUARE HEAD BOLT	4
	HD-80200-2	B	726273	M8-1.25 x 40mm SQUARE HEAD BOLT	2
	HD-80206	E	726274	M8-1.25 HEX NUT	6
HD-80208		726275	M8-1.25 ROUND HEAD BOLT	2	
HD-80214	G	726276	M8 WASHER	4	
HD-80183	Q	726277	WHEEL, WORK SUPPORT	2	
EXTENSION STOP	AX-11098-2		726278	STOP PIPE	1
	AX-11104		726279	STOP COLLAR	1
	AX-11110		726280	SWIVEL STOP	1
	HD-80187	W	726281	1/2 WASHER	1
	HD-80207	X	726282	M6-1.0 SQUARE NUT	1
	HD-80212	V	726283	M6-1.0 X 30MM SOCKET HEADCAP SCREW	1
	KB-90020	S	726210	KNOB, 3/8-16 NYLON TIP	1
	KB-90022	R	726284	KNOB, 1/2-13	1

This Universal Workstation is designed to be used with:

<p>Hitachi C8FB2, C10FCB, C10FS, C10FSB, C10FCE, C10FCH, C10FSH, C12LCH, C12FCH, C12LC, C12LDH, C12FDH.</p> <p>Bosch 3915, 3912, 4412.</p>	<p>Delta MS150, 36.075, 36.225, 36-085, 36-225, 36-585, M275, MS250, MS350, 36-255, 36-255L, MS450.</p> <p>DeWalt DW703, DW 708, DW705, DW706, DW706, DW709, DW715, DW716.</p>	<p>Makita LS1011N, LS1013, LS1212, LS1220, LS1221.</p> <p>Milwaukee 6490.</p> <p>Porter-Cable 3807, 3802.</p>	<p>Rigid MS1065LZ, MS1250LZ, MS1290LZ.</p> <p>Ryobi TS1301, TS1340, TS1350DX, TS1352DXL, MS1250LS, S1551DXL.</p> <p>Sears Craftsman 137.212000, 72.24360, 315.21213, 315.212400, 315.212500, 137.212924, 315.212240, 009.23240, 009.29723.</p>
--	--	--	---

TROUBLE-SHOOTING TIPS.

Issue: Support Arm Assembly has problems sliding, or handle is too “loose” or too “tight”.

Solution: Remove any debris from beam slots. Re-Adjust handle bolt tightness. (see below).



To adjust the tension of the bolt, keep handle in the down position, back nut off, adjust bolt tension and re-tighten nut.

Issue: “T” Track or “T” slot on Baserail is damaged.

Solution: File track or slot with flat file to remove burr/bump.

Issue: Saw is unstable when the “Toolmount Handles” are put in the unlock position to remove saw.

Solution: Loosen the Toolmount Beam fasteners (to the saw or Toolmount) and re-position the saw, forward or back, on the Toolmount Bases.

- Re-positioning the saw will balance it, for ease of removal and installation to the baserail, when the handles are in the unlock position.
- For sliding miter saws, sliding and locking the saw motor & blade to an alternate position during removal and installation should sufficiently stabilize the saw/toolmount unit.

Issue: Saw has rubber foot pads on the saw base that make tool mount installation difficult.

Solution: Remove rubber foot pads

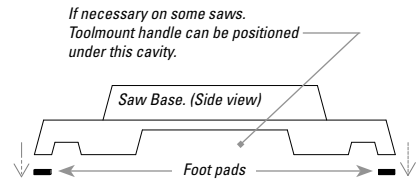

Issue: Work support is not horizontal or parallel with the saw table or other support.

Solution: Change angle by placing 5/16” washer between the support beam and “T”. Re-tighten nuts.

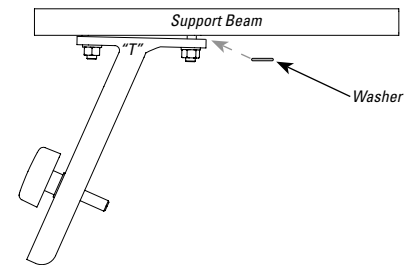

IMPORTANT SAFETY INSTRUCTIONS FOR USING THIS UNIVERSAL WORKSTATION

1. Read the Universal Workstation instruction manual care-fully before assembling the workstation and mounting the miter saw.
2. This Universal Workstation is designed to be used with **Hitachi** (C8FB2, C10FCB, C10FS, C10FSB, C10FCE, C10FCH, C10FSH, C12LCH, C12FCH, C12LC, C12FDH, C12LDH), **Bosch** (3915, 3912, 4412), **Delta** (MS150, 36.075, 36.225, 36-085, 36-225, 36-585, M275, MS250, MS350, 36-255, 36-255L, MS450), **DeWalt** (DW703, DW 708, DW705, DW706, DW706, DW709, DW715, DW716), **Makita** (LS1011N, LS1013, LS1212, LS1220, LS1221), **Milwaukee** (6490), **Porter-Cable** (3807, 3802), **Rigid** (MS1065LZ, MS1250LZ, MS1290LZ), **Ryobi** (TS1301, TS1340, TS1350DX, TS1352DXL, MS1250LS, S1551DXL), **Sears Craftsman** (137.212000, 72.24360, 315.21213, 315.212400, 315.212500, 137.212924, 315.212240, 009.23240, 009.29723), Miter Saws. Use with additional Miter Saw models has not yet been verified.
3. The Miter Saw should be firmly mounted to the Universal Workstation per the instruction manual.
4. After mounting the Miter Saw to the Universal Workstation, align, position and balance the Miter Saw.
5. Before use, verify that all Universal Workstation parts are free from damage and/ or deformity.
6. Before use, verify that all parts or components of the Universal Workstation are properly installed.
7. Before use, swing open each of the legs until the brass pin clicks, locking the legs in position.
8. When mounting the Miter Saw to the Universal Workstation, make sure that the tool mount handles are in the “UNLOCK” position, so the tool mount will engage with the main beam. Be sure to hold the saw until it is secured to prevent it from falling off the main beam. Handles should then be tightened.
9. Before operating the Miter Saw, confirm that the tool mount handles on both sides of this Universal Workstation are firmly tightened ensuring that the Miter Saw is securely mounted to the Workstation.
10. When removing the Miter Saw from the Universal Workstation, loosen the tool mount handles until they rotate to the “UNLOCK” position. Hold the Miter Saw firmly to prevent the saw from falling off the main beam. Carefully remove the Miter Saw.
11. Disconnect the power plug from the power outlet when mounting or dismounting the Miter Saw to the Universal Workstation.
12. Do not modify the Universal Workstation in any manner or use the Universal Workstation for any purpose other than is stated in these instructions.
13. Do not sit or stand on the Universal Workstation. Do not place, hang, or install anything on the Universal Workstation other than a Miter Saw.
14. Always use this universal workstation on a level surface. Do not use it on uneven or unstable surfaces.
15. Before operating the mounted Miter Saw, read the Miter Saw instruction manual carefully.
16. Because cut material may cause the workstation to become unbalanced, always be sure the material is supported properly. Also, if the piece being cut is placed far beyond the work support, workstation legs on the opposite side may suddenly be lifted up due to weight imbalance. To prevent this from occurring, hold the opposite side firmly before cutting.

Customer Service 508-677-4130

HITACHI

Hitachi-Koki, USA, Ltd

	P/N	ARTICULO	HITACHI P/N.	DESCRIPCION	CALIDAD
RIEL BASE y PATAS	AX-11096-B		726220	RIEL BASE	1
	AX-14403-5		726222	PATA DE ALUMINIO	4
	01-25517		726223	SOPORTE DE LA PATA	2
	PI-11005		726224	TAPA PARA EXTREMOS DEL RIEL BASE	2
	RI-14208		726225	INSERTO PARA PIE	4
	SP-14201		726226	TRABA DEL RESORTE	4
	HD-80021		726227	TUERCA HEXAGONAL CON TRABA AUTOMATICA DE 3/8 - 16	4
	HD-80033		726228	TORNILLO DE CAPUCHON de 3/8 - 16 x 2.38	4
	HD-80034		726229	REMATE DE 1/8 x 3/8	8
	HD-80035		726230	REMATE DE 1/4 x 5/8	8
	HD-80210	H	726231	TORNILLO AUTORROSCANTE CON ARANDELA DE CABEZA HEXAGONAL DE ST 6.3 mm x 20 mm	4
SOPORTE PARA DISCO	01-25518		726232	SOPORTE PARA DISCO	1
	HD-80078	L	726233	ARANDELA DE 3/8	2
	HD-80150		726234	DISCO CON BUJE	2
	HD-80153	M	726235	TAPA A PRESION	2
	HD-80154	N	726236	ARANDELA DE 1/2	2
	HD-80155		726237	VARILLA DE 3/8	1
	HD-80204	K	726238	TUERCA HEXAGONAL CON TRABA AUTOMATICA M6 DE 1.0	4
	HD-80217	J	726239	TORNILLO DE CABEZA OVALADA M6 DE 1.0 mm x 16 mm	4
MONTAJE DE HERRAMIENTAS	ZN-11501		726240	ABRAZADERA PARA EL MONTAJE DE HERRAMIENTAS	2
	ZN-11099		726241	SUJETADOR PARA EL MONTAJE DE HERRAMIENTAS	2
	ZN-11504		726242	MANGO DE SUJECION METRICO	2
	AX-11101		726243	LLAVE	2
	AX-11102-2		726206	VIGA DE SOPORTE DE 18 PULGADAS	2
	01-25512		726244	PLACA ADAPTADORA PARA SIERRA	1
	PI-11008	O	726245	PIE PARA EL MONTAJE DE HERRAMIENTAS	4
	SP-14202		726246	RESORTE CONICO	2
	HD-80199-1		726247	PERNOS HEXAGONALES M8 DE 1.25 mm x 50 mm	2
	HD-80200-1	A	726248	PERNOS DE CABEZA CUADRADA M8 DE 1.25 mm x 20 mm	6
	HD-80200-2	B	726249	PERNOS DE CABEZA CUADRADA M8 DE 1.25 mm x 40 mm	3
	HD-80200-3	C	726250	PERNOS DE CABEZA CUADRADA M8 DE 1.25 mm x 50 mm	4
	HD-80205	F	726251	TUERCA HEXAGONAL CON TRABA AUTOMATICA M8 DE 1.25	11
	HD-80206	E	726252	TUERCA HEXAGONAL M8 DE 1.25	2
	HD-80211	D	726253	TORNILLO AUTORROSCANTE CON CABEZA HEXAGONAL ST DE 6.3 mm x 25 mm	4
	HD-80214	G	726254	ARANDELA M8	13

	P/N	ARTICULO	HITACHI P/N.	DESCRIPCION	CALIDAD
BRAZO DE SOPORTE	AX-11118		726285	BRAZO DE SOPORTE	2
	AX-11102-1		726257	VIGA DE SOPORTE DE 12 PULGADAS	2
	ZN-11504		726259	MANGO DE SUJECION METRICO	2
	ZN-11108		726260	BASE DE LA PRENSA	2
	ZN-11500		726261	ADAPTADOR DE SOPORTE	2
	ZN-11503		726262	SOPORTE DE TRABAJO	2
	KB-90021	P	726263	PERILLA DE 3/8 - 16	2
	PI-11004		726265	BASE GUIA	4
	PI-11017		726266	TAPA PARA EXTREMOS	4
	HD-11109		726267	BASE GUIA CON PERNO	2
	HD-12021		726268	TUERCA REMACHE DE 3/8 -16	2
	HD-80034		726269	REMATE DE 1/8 x 3/8	8
	HD-80078	L	726270	ARANDELA DE 3/8	2
	HD-80192		726271	REMATE DE 1/8 x 5/8	2
	HD-80200-1	A	726272	PERNOS DE CABEZA CUADRADA M8 DE 1.25 mm x 20 mm	4
	HD-80206	E	726274	TUERCA HEXAGONAL M8 DE 1.25	6
	HD-80208		726275	TUERCA HEXAGONAL M8 DE 1.25	2
HD-80214	G	726276	ARANDELA M8	4	
TOPE DE LA EXTENSION	AX-11098-2		726278	TUBO DE CIERRE	1
	AX-11104		726279	ANILLO DE CIERRE	1
	AX-11110		726280	TOPE GIRATORIO	1
	HD-80187	W	726281	ARANDELA DE 1/2	1
	HD-80207	X	726282	TUERCA CUADRADA M6-1.0	1
	HD-80212	V	726283	TORNILLO DE CABEZA DE CAPUCHON M6-1.0 X 30 MM	1
	KB-90020	S	726210	PERILLA DE 3/8 -16 CON PUNTA DE NYLON	1
	KB-90022	R	726284	PERILLA DE 1/2 -13	1

Esta estación de trabajo universal está diseñada para ser utilizada con sierras ajustables para ángulos:

<p>Hitachi C8FB2, C10FCB, C10FS, C10FSB, C10FCE, C10FCH, C10FSH, C12LCH, C12FCH, C12LC, C12LDH, C12FDH.</p> <p>Bosch 3915, 3912, 4412.</p>	<p>Delta MS150, 36.075, 36.225, 36-085, 36-225, 36-585, M275, MS250, MS350, 36-255, 36-255L, MS450.</p> <p>DeWalt DW703, DW 708, DW705, DW706, DW706, DW709, DW715, DW716.</p>	<p>Makita LS1011N, LS1013, LS1212, LS1220, LS1221.</p> <p>Milwaukee 6490.</p> <p>Porter-Cable 3807, 3802.</p>	<p>Rigid MS1065LZ, MS1250LZ, MS1290LZ.</p> <p>Ryobi TS1301, TS1340, TS1350DX, TS1352DXL, MS1250LS, S1551DXL.</p> <p>Sears Craftsman 137.212000, 72.24360, 315.21213, 315.212400, 315.212500, 137.212924, 315.212240, 009.23240, 009.29723.</p>
--	--	--	---

CONSEJOS PARA LA SOLUCION DE PROBLEMAS

Problema: El ensamblado del brazo de soporte tiene problemas con el deslizamiento, o la manija está demasiado "floja" o demasiado "ajustada".

Solución: Quite los desechos de las ranuras de las vigas. Reajuste la tensión del perno de la manija. (Vea la ilustración de abajo).



Para ajustar la tensión del perno, mantenga la manija en la posición inferior, desajuste la tuerca, ajuste la tensión del perno y vuelva a ajustar la tuerca.

Problema: El carril o la ranura en forma de "T" del riel base están dañados.

Solución: Lime el carril o la ranura con una lima plana para quitar las rebabas o las abolladuras.

Problema: La sierra queda inestable cuando se aflojan las "manijas para montaje de herramientas" para extraer la sierra.

Solución: Afloje los sujetadores para montaje de herramientas de la viga (de la sierra o de las bases para montaje de herramientas) y vuelva a ubicar la sierra, hacia delante o hacia atrás, en las bases para montaje de herramientas.

- La reubicación de la sierra la balanceará, para facilitar la extracción y la instalación en el riel base, cuando las manijas estén en la posición desbloqueada.
- En el caso de las sierras ajustables para ángulos, el deslizamiento y el bloqueo del motor y la hoja de la sierra en una posición alternativa deberían ser suficientes para estabilizar la sierra o la unidad para montaje de herramientas.

Problema: Las almohadillas de hule que la sierra tiene en las patas de la base dificultan la instalación.

Solución: Quite las almohadillas de hule de las patas

Si es necesario, en algunas sierras, el mango del soporte para herramientas puede ser colocado debajo de esta cavidad.

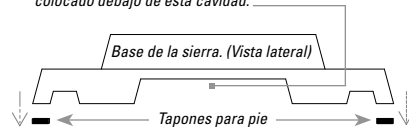

Problema: El soporte de trabajo no está horizontal o paralelo a la mesa de la sierra o a otros soportes.

Solución: Cambie el ángulo, colocando una arandela de 5/16" entre la viga de soporte y la "T". Vuelva a ajustar las tuercas.

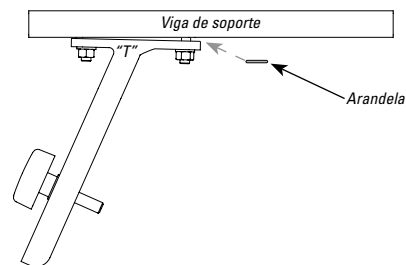

INSTRUCCIONES IMPORTANTES DE SEGURIDAD PARA UTILIZAR ESTA ESTACION DE TRABAJO UNIVERSAL

1. Lea completamente el manual de instrucciones de la estación de trabajo universal antes de ensamblarla y de montar la sierra ajustable para ángulos.
2. Esta estación de trabajo universal está diseñada para ser utilizada con sierras ajustables para ángulos **Hitachi** (C8FB2, C10FCB, C10FS, C10FSB, C10FCE, C10FCH, C10FSH, C12LCH, C12FCH, C12LC, C12FDH, C12LDH), **Bosch** (3915, 3912, 4412), **Delta** (MS150, 36.075, 36.225, 36-085, 36-225, 36-585, M275, MS250, MS350, 36-255, 36-255L, MS450), **DeWalt** (DW703, DW 708, DW705, DW706, DW706, DW709, DW715, DW716), **Makita** (LS1011N, LS1013, LS1212, LS1220, LS1221), **Milwaukee** (6490), **Porter-Cable** (3807, 3802), **Rigid** (MS1065LZ, MS1250LZ, MS1290LZ), **Ryobi** (TS1301, TS1340, TS1350DX, TS1352DXL, MS1250LS, S1551DXL), **Sears Craftsman** (137.212000, 72.24360, 315.21213, 315.212400, 315.212500, 137.212924, 315.212240, 009.23240, 009.29723). El uso con otros modelos adicionales de sierras ajustables para ángulos no se ha probado todavía.
3. La sierra ajustable para ángulos debe montarse firmemente en la estación de trabajo universal según las instrucciones del manual.
4. Una vez que haya montado la sierra ajustable para ángulos en la estación de trabajo universal, alinee, ubique y balancee la sierra ajustable para ángulos.
5. Antes de usarla, verifique que todas las partes de la estación de trabajo universal no presenten deterioros y/o deformidades.
6. Antes de utilizar la estación de trabajo universal, verifique que todas las piezas y los componentes estén instalados correctamente.
7. Antes de utilizarla, abra cada una de las patas hasta que el pasador de latón haga clic y bloquee las patas en su posición.
8. Cuando monte la sierra ajustable para ángulos en la estación de trabajo universal, asegúrese de que las manijas para montaje de herramientas estén en la posición "DESBLOQUEADA", para que la base para montaje de la herramienta calce en la viga principal. Asegúrese de sostener la sierra hasta que esté asegurada para evitar que se caiga de la viga principal. Luego, debe ajustar las manijas.
9. Antes de poner en funcionamiento la sierra ajustable para ángulos, compruebe que las manijas para montaje de herramientas estén firmemente ajustadas, para asegurarse de que la sierra ajustable para ángulos esté montada de manera segura en la estación de trabajo universal.
10. Cuando extraiga la sierra ajustable para ángulos de la estación de trabajo universal, gire las manijas de montaje hasta que queden en la posición "DESBLOQUEADA". Sostenga firmemente la sierra ajustable para ángulos a fin de evitar que se caiga de la viga principal. Extraiga cuidadosamente la sierra ajustable para ángulos.
11. Cuando monte o la sierra ajustable para ángulos en la estación de trabajo universal o cuando la desmonte, desconecte el enchufe del tomacorriente.
12. No modifique de ninguna manera la estación de trabajo universal ni la utilice para otros propósitos que no sean los que están especificados por estas instrucciones.
13. No se siente ni se pare en la estación de trabajo universal. No cuelgue, no cuelgue ni instale en la estación de trabajo universal otra cosa que no sea la sierra ajustable para ángulos.
14. Utilice siempre esta estación de trabajo universal en una superficie nivelada. No la utilice en superficies desparejas o inestables.
15. Antes de poner en funcionamiento la sierra ajustable para ángulos una vez que esté montada, lea atentamente el manual de instrucciones de la sierra.
16. Dado que el material que se va a cortar puede hacer que la estación de trabajo pierda el balance, asegúrese siempre de que el material esté sujetado correctamente. Además, si la pieza que se va a cortar está ubicada más allá del soporte de trabajo, las patas del lado opuesto pueden levantarse súbitamente a causa del mal balanceo del peso. Para evitar que esto ocurra, sostenga firmemente el lado opuesto antes de realizar el corte.

Servicio De Cliente 508-677-4130

HITACHI

Hitachi-Koki, USA, Ltd

UIU610_IM-A02