

# ELECTRIC TOOL PARTS LIST

■ CORDLESS IMPACT DRIVER DRILL 2005 · 3 · 10  
Model DV 18DMR (E1)

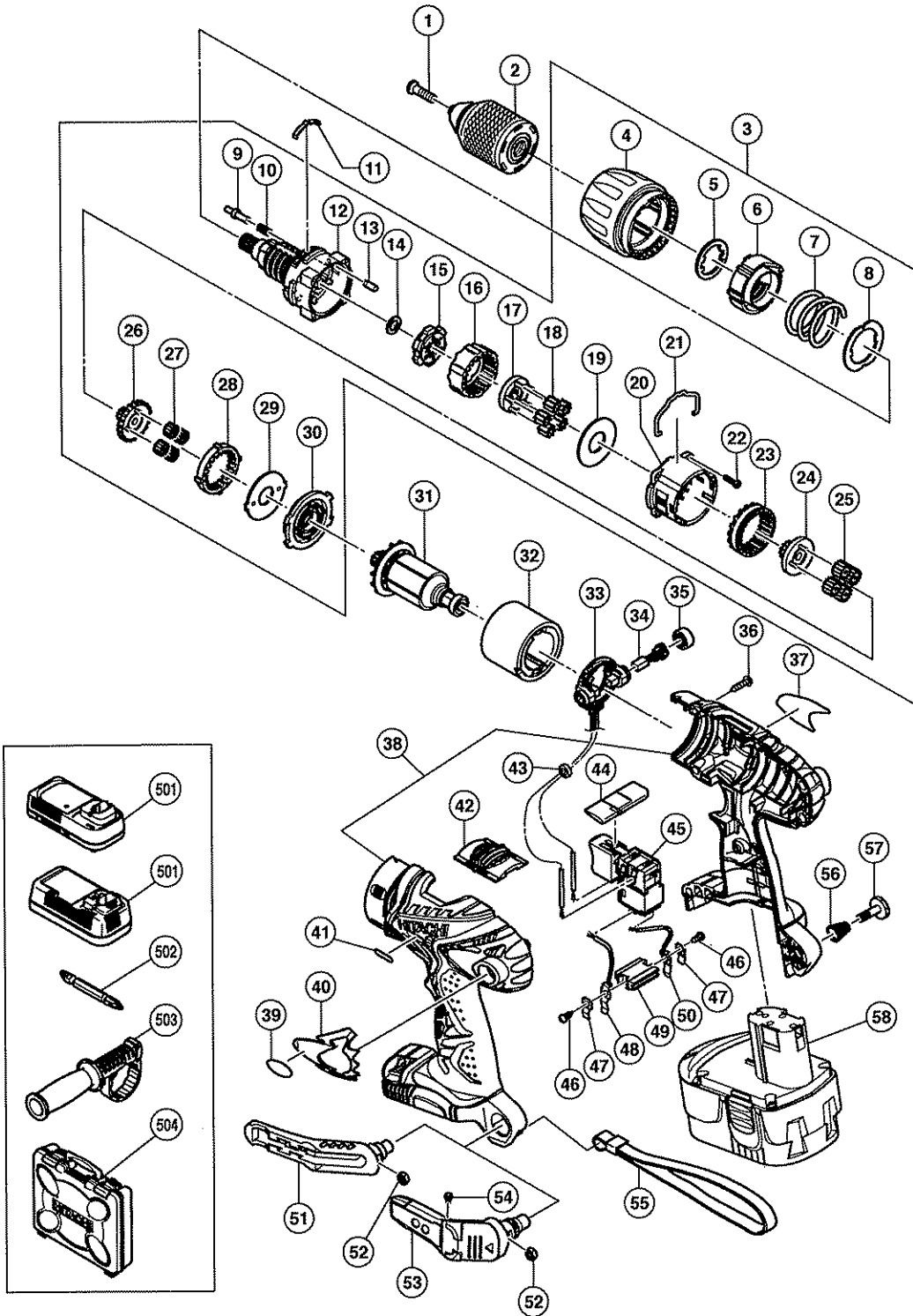

## PARTS

DV 18DMR

ITEM NO.	CODE NO.	DESCRIPTION	NO. USED	REMARKS
1	311-959	SPECIAL SCREW (LEFT HAND) M6X23	1	
2	323-898	DRILL CHUCK 13VLRN-N (W/O CHUCK WRENCH)	1	
3	324-061	GEAR BOX ASS'Y	1	INCLUD. 4-10, 12-30
4	324-074	FRONT CAP	1	
5	324-136	SWITCH PLATE	1	
6	324-064	NUT	1	
7	324-135	SPRING	1	
8	324-063	THRUST WASHER	1	
9	322-972	STOPPER	2	
10	322-971	STOPPER SPRING	2	
11	320-773	CLICK SPRING	1	
12	324-062	FRONT CASE	1	
13	322-975	PIN SET (6 PCS.)	6	
14	324-065	WASHER (D)	1	
15	322-976	LOCK RING	1	
16	324-066	RING GEAR	1	
17	322-978	CARRIER	1	
18	324-067	PLANET GEAR (C) SET (5 PCS.)	5	
19	322-980	WASHER (A)	1	
20	322-981	REAR CASE	1	
21	322-990	SHIFT ARM	1	
22	320-087	SCREW SET M3X12 (4 PCS.)	4	
23	324-069	SLIDE RING GEAR	1	
24	324-068	PINION (C)	1	
25	324-070	PLANET GEAR (B) SET (4 PCS.)	4	
26	324-071	PINION (B)	1	
27	324-073	PLANET GEAR (A) SET (4 PCS.)	4	
28	324-072	FIRST RING GEAR	1	
29	322-988	WASHER (B)	1	
30	322-989	MOTOR SPACER	1	
31	360-701	ARMATURE AND PINION SET	1	
32	322-996	MAGNET	1	
33	322-993	BRUSH BLOCK	1	
34	999-054	CARBON BRUSH 5X6X11.5 (1 PAIR)	2	
35	319-918	BRUSH CAP	2	
36	313-687	TAPPING SCREW (W/FLANGE) D3X16 (BLACK)	10	
37		NAME PLATE	1	
38	322-998	HOUSING (A). (B) SET	1	
39		LABEL	1	
40	322-999	PLATE (A)	1	
41		HITACHI LABEL	1	
42	324-137	SHIFT KNOB	1	
* 43	323-229	FERRITE CORE	1	EXCEPT FOR NZL, AUS, USA, CAN
44	322-997	PUSHING BUTTON	1	
45	322-994	DC-SPEED CONTROL SWITCH	1	
46	958-715	TAPPING SCREW D4X10	2	
47	996-118	HOLDER SPRING	2	
48	322-995	TERMINAL	1	
49	320-997	TERMINAL PIECE	1	
50	323-003	TERMINAL	1	
* 51	320-287	HOOK ASS'Y	1	INCLUD. 52





ELECTRIC TOOL PARTS LIST

■ CORDLESS CIRCULAR SAW  
Model C 18DMR

2005 · 6 · 1  
(E1)

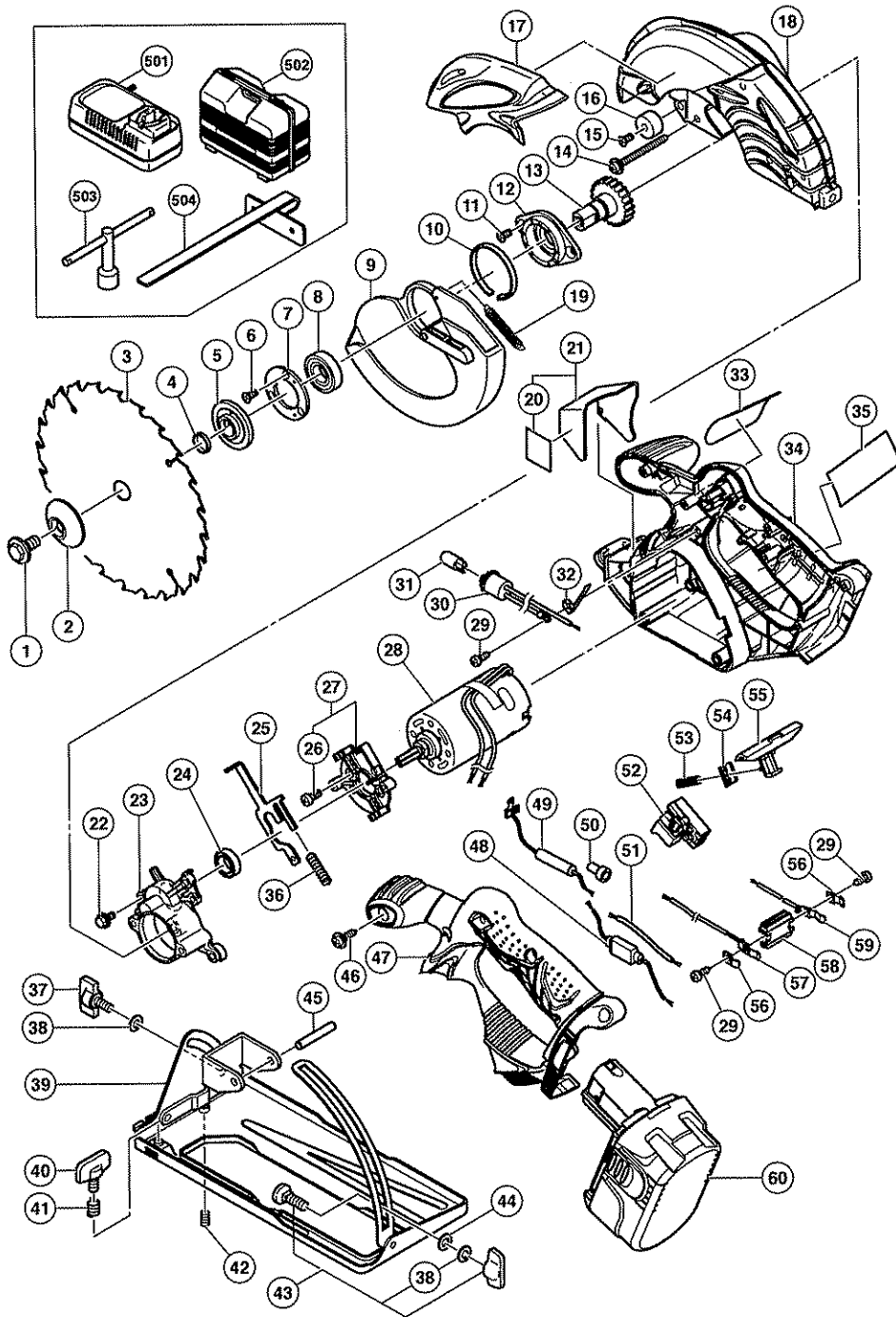

## PARTS

C 18DMR

ITEM NO.	CODE NO.	DESCRIPTION	NO. USED	REMARKS
1	998-335	BOLT (LEFT HAND) W/WASHER M7X17.5	1	
2	324-563	WASHER (B2)	1	
* 3	324-295	TCT SAW BLADE 165MM-D30 HOLE-NT24	1	
* 3	324-294	TCT SAW BLADE 165MM-D20 HOLE-NT24	1	FOR NZL, AUS, CHN
* 3	324-293	TCT SAW BLADE 165MM-D15.9 HOLE-NT24	1	FOR USA, CAN
* 3	324-615	TCT SAW BLADE 165MM-D15.9 HOLE-NT24	1	FOR FRA
* 4	990-100	RING D15.9/I.D14.5	1	FOR FRA, USA, CAN
* 5	317-465	WASHER (A2)	1	
* 5	324-569	WASHER (A3)	1	FOR GBR, FRG, FRA, NOR, SWE, DEN
* 5	317-466	WASHER (A1)	1	FOR FRA, USA, CAN
6	308-773	SEAL LOCK FLAT HD. SCREW M3X12	3	
7	308-362	BEARING COVER	1	
8	600-2VV	BALL BEARING 6002VVCMP2L	1	
9	324-567	PROTECTIVE COVER	1	
10	318-192	BUSHING	1	
11	305-568	SEAL LOCK FLAT HD. SCREW M5X12	2	
12	308-361	BEARING HOLDER	1	
13	324-564	GEAR	1	
14	317-449	TAPPING SCREW (W/FLANGE) D5X50	3	
15	949-793	FLAT HD. SCREW M5X20 (10 PCS.)	1	
16	310-842	CUSHION	1	
17	324-560	HITACHI PLATE	1	
18	324-566	SAW COVER	1	
19	317-203	RETURN SPRING	1	
20		LABEL (LC)	1	
21	324-577	LIGHT COVER ASS'Y	1	INCLUD. 20
22	317-196	NYLOCK BOLT (W/FLANGE) M4X12	2	
23	324-565	INNER COVER (B)	1	
24	609-VVM	BALL BEARING 609VVC2PS2L	1	
25	324-568	LOCK LEVER	1	
26	317-914	SPECIAL BOLT M5	2	
27	324-578	INNER COVER (A) ASS'Y	1	INCLUD. 26
28	324-572	MOTOR (B)	1	
29	958-715	TAPPING SCREW D4X10	3	
30	319-820	SOCKET	1	
31	315-229	LAMP (12V 5W)	1	
32	319-823	TERMINAL (D)	1	
33		NAME PLATE	1	
34	324-575	HOUSING	1	
* 35		CAUTION PLATE	1	FOR USA, CAN
36	961-803	SPRING	1	
37	308-364	WING BOLT (A) M6X15	1	
38	948-167	SUPER LOCK WASHER M6	2	
39	324-561	BASE ASS'Y	1	INCLUD. 37, 38, 40-42
40	324-562	KNOB BOLT	1	
41	947-859	LOCK SPRING	1	
42	302-469	SLOTTED HD. SET SCREW (SEAL LOCK) M6X6	1	
43	314-620	BOLT ASS'Y (SQUARE) M6X22	1	INCLUD. 38
44	949-425	WASHER M6 (10 PCS.)	1	
45	949-750	ROLL PIN D6X50 (10 PCS.)	1	
46	305-812	TAPPING SCREW (W/FLANGE) D4X16 (BLACK)	6	







## ELECTRIC TOOL PARTS LIST

■ CORDLESS RECIPROCATING SAW 2005 · 4 · 15  
Model CR 18DMR (E1)

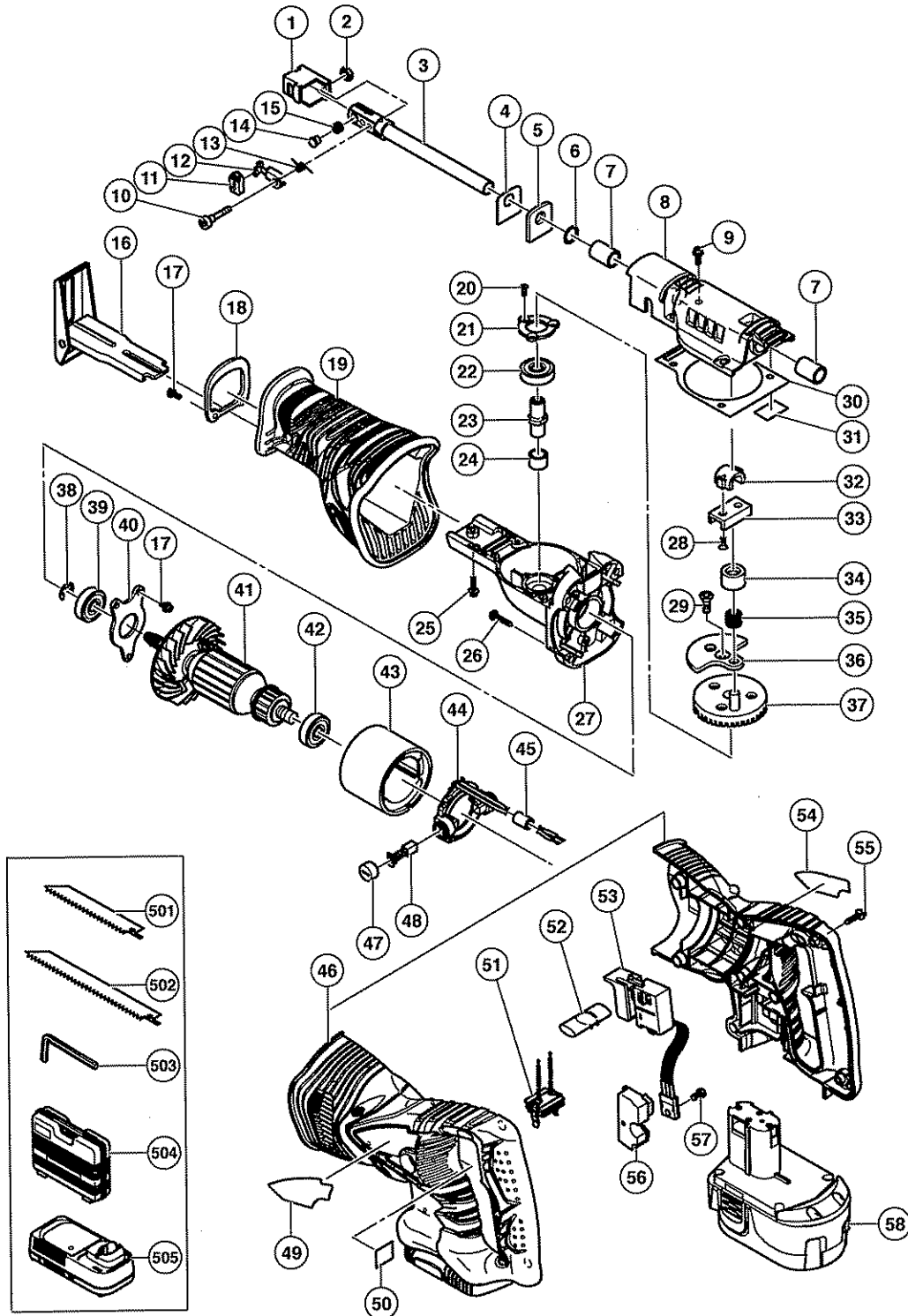

## PARTS

CR 18DMR

ITEM NO.	CODE NO.	DESCRIPTION	NO. USED	REMARKS
1	321-132	BLADE HOLDER (A)	1	
2	322-709	NUT M4 (BLACK)	1	
3	324-472	PLUNGER	1	
4	996-401	PACKING WASHER	1	
5	996-400	FELT PACKING	1	
6	996-407	O-RING (1AP-12)	1	
7	956-589	METAL	2	
8	324-471	UPPER COVER	1	
9	305-574	HEX. SOCKET HD. BOLT (W/SP. WASHER) M5X16	4	
10	322-134	SPECIAL BOLT M4	1	
11	321-130	CAP	1	
12	321-131	LEVER (A)	1	
13	321-135	SPRING (D)	1	
14	321-134	HOLDER PIN (B)	1	
15	318-483	SPRING (B)	1	
16	319-866	BASE	1	
17	951-039	MACHINE SCREW (W/SP. WASHER) M4X12	5	
18	324-474	COVER PLATE	1	
19	324-473	FRONT COVER	1	
20	993-244	SEAL LOCK FLAT HD. SCREW M4X12	3	
21	319-849	BEARING COVER (B)	1	
22	690-1ZZ	BALL BEARING 6901ZZCMPS2L	1	
23	319-848	SPINDLE	1	
24	954-789	METAL (B)	1	
25	996-399	HEX. SOCKET HD. BOLT (W/FLANGE) M5X12	1	
26	986-011	TAPPING SCREW (W/SP. WASHER) D5X30	4	
27	319-844	GEAR COVER ASS'Y	1	INCLUD. 24
28	319-875	SEAL LOCK HEX. SOCKET FLAT HD. BOLT M5X12	2	
29	319-851	NYLOCK HEX. SOCKET FLAT HD. BOLT M6X16	1	
30	319-856	SEAL PACKING	1	
31	319-874	PACKING (B)	1	
32	983-567	CONNECTOR HOLDER	1	
33	996-405	CONNECTOR	1	
34	983-541	CONNECTING PIECE (A)	1	
35	324-470	NEEDLE ROLLER	1	
36	319-852	BALANCE WEIGHT	1	
37	324-469	GEAR	1	
38	670-514	RETAINING RING (E-TYPE) FOR D10 SHAFT	1	
39	600-1VV	BALL BEARING 6001VVCMP2L	1	
40	319-843	BEARING COVER (A)	1	
41	360-703	ARMATURE ASS'Y DC 18V	1	INCLUD. 38-40, 42
42	608-VVM	BALL BEARING 608VVC2PS2L	1	
43	324-468	MAGNET	1	
44	324-478	BRUSH BLOCK	1	
* 45	318-247	FERRITE CORE	1	EXCEPT FOR AUS, NZL, USA, CAN, CHN
46	324-475	HOUSING (A). (B) SET	1	
47	319-847	BRUSH CAP	2	
48	999-058	CARBON BRUSH (1 PAIR)	2	
49		HITACHI LABEL	1	
50		CAUTION LABEL	1	
51	324-517	TERMINAL PIECE	1	



