

Tanaka Illustrated Parts Manual

Model Number:

HTD-2530PF

30" DOUBLE-SIDED HEDGETRIMMER

P/N 30232

Rev 000

Date 9-17-08



Nikko Tanaka Engineering U.S.A.,Ltd. • 1028 4th Street SW, Bldg B • Auburn, WA 98001 • Phone: (253) 333-1200 • Fax: (253) 333-1212

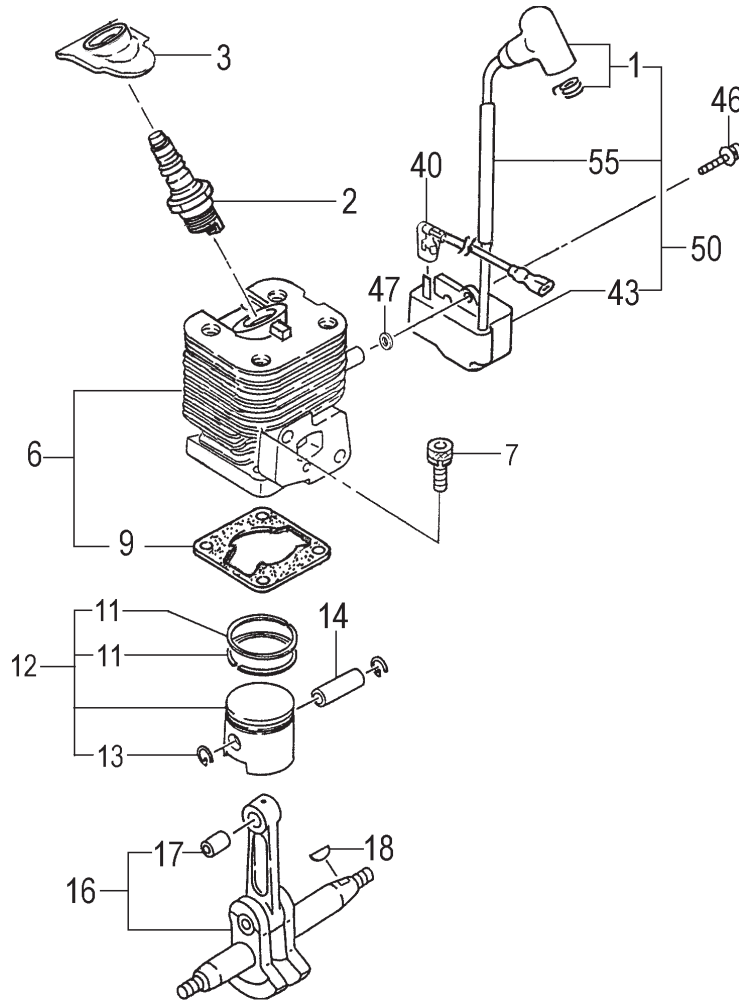

ITEM	PART NUMBER	DESCRIPTION	QTY	COMMENTS
1-1	1570168090	CAP, SPARK PLUG ASS'Y	1	
1-2	0181166021	PLUG, SPARK	1	
1-3	2550168020	COVER, SPARK PLUG, RUBBER	1	
1-6	0010300290	SET, CYLINDER	1	Includes gasket
1-7	99461050184	BOLT, HEX, 5X18, S	4	
1-9	0170300220	GASKET, CYLINDER	1	
1-11	04101601200	RING, PISTON	2	
1-12	0300168090	PISTON SET	1	Includes rings and circlips
1-13	03900000201	CIRCLIP, PISTON PIN	2	
1-14	03701700200	PIN, PISTON	1	
1-16	0460300280	CRANKSHAFT	1	
1-17	99962091325	BEARING, NEEDLE, F-910	1	
1-18	06810100200	KEY, WOODRUFF, 3X13X4.5	1	
1-40	1780300280	CORD, B, 140M	1	
1-46	99464040184	BOLT, HEX, 4X18WS	2	
1-47	1820186A201	WASHER, SPECIAL	2	
1-50	1672174390	COIL, IGNITION ASS'Y	1	
1-55	2500168020	TUBE, INSULATOR	1	

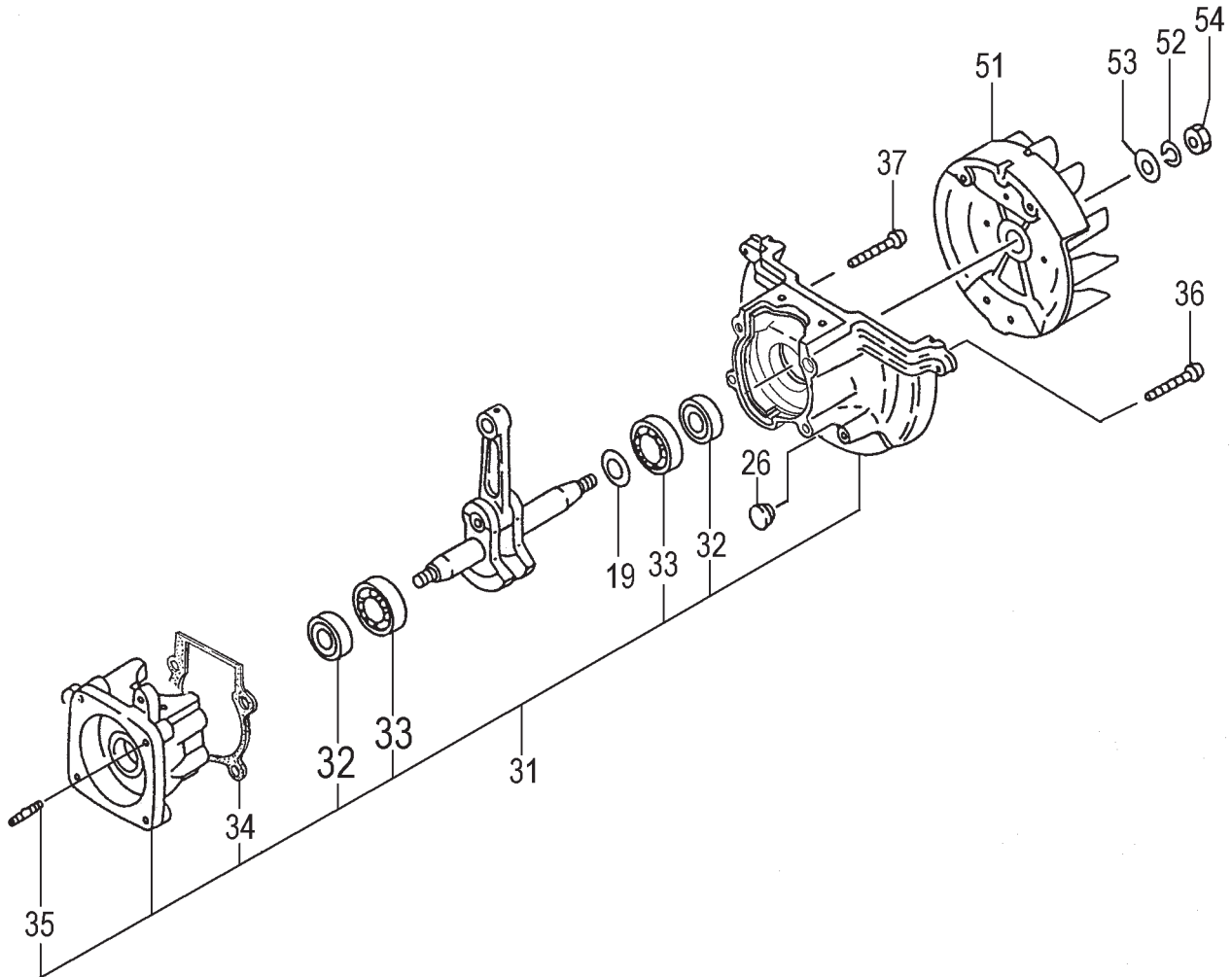

ITEM	PART NUMBER	DESCRIPTION	QTY	COMMENTS
2-19	33000200210	SHIM,12.2X19X.10	1	
2-19	33000200220	SHIM,12.2X19X.15	1	
2-19	33000200230	SHIM,12.2X19X.20	1	
2-19	33000200240	SHIM,12.2X19X.30	1	
2-26	2030300220	GROMMET	1	
2-31	0720300290	CRANKCASE	1	Includes bearings, seals and gasket
2-32	99966122240	R-B 99966122206 SEAL,OIL	2	
2-33	99961600115	BEARING,BALL,6001 C3	2	
2-34	0900300220	GASKET,CRANKCASE	1	
2-35	10002100200	BOLT,STUD,6X22	2	
2-36	99461050304	BOLT,HEX,5X30S	2	
2-37	99414050451	SCREW,5X45/S	2	~A091000
2-37	99051050453	BOLT,HEX,5X45	2	A091001~
2-38	99210050062	WASHER,S,5	2	A091001~
2-51	1552174480	MAGNETO	1	
2-52	99210080012	WASHER,S,8	1	
2-53	99201080011	WASHER,8	1	
2-54	99101080011	NUT,8	1	

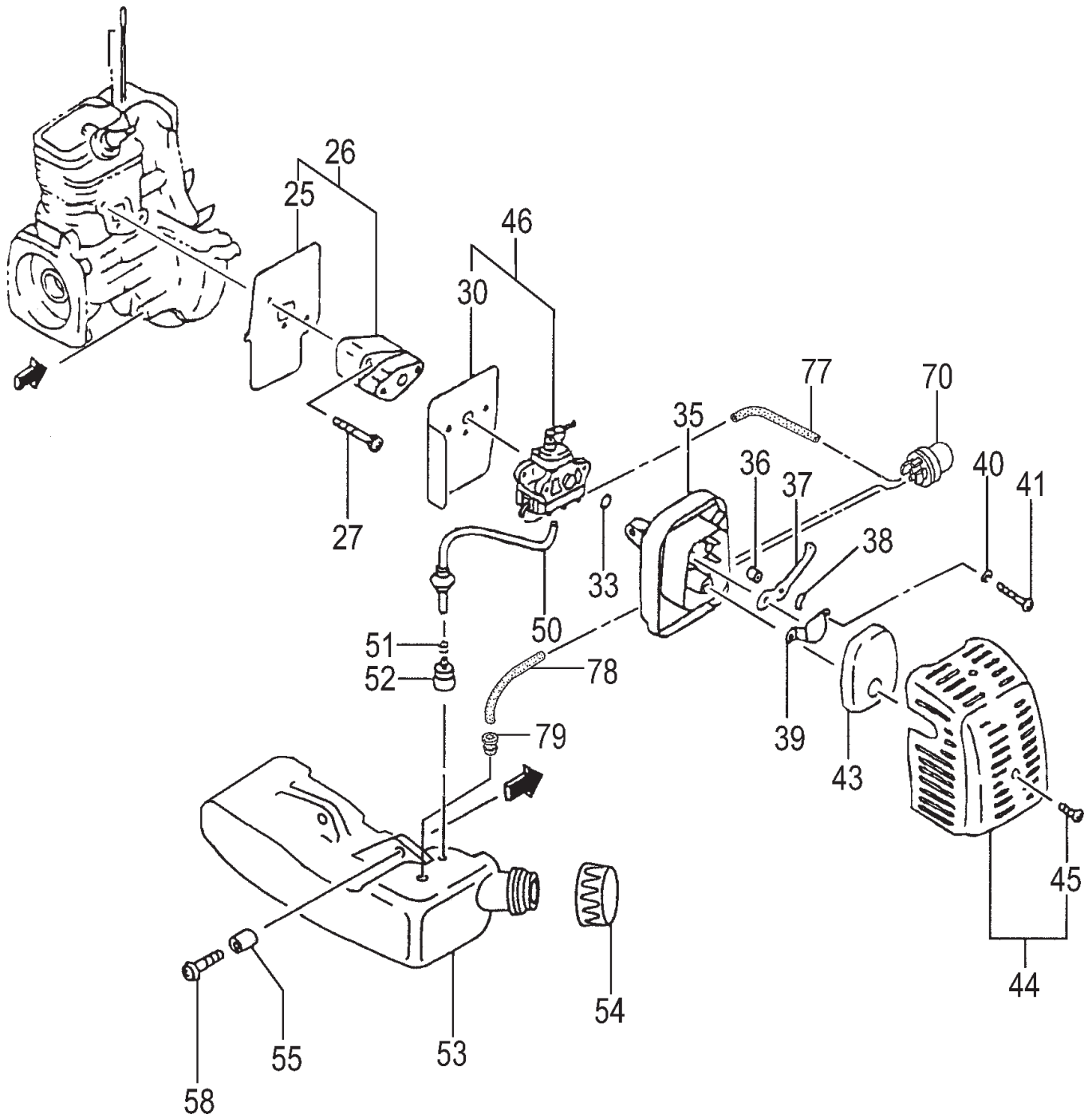

ITEM	PART NUMBER	DESCRIPTION	QTY	COMMENTS
3-25	4030300220	GASKET,INTAKE	1	Includes gasket
3-26	4040300291	INSULATOR SET	1	
3-27	99464050254	BOLT,HEX HOLE,5X25WS	2	
3-30	4020300220	GASKET,CARBURETOR	1	
3-33	99967015000	O-RING,P15	1	
3-35	4230650081	BODY,CLEANER	1	
3-36	47006500200	COLLAR	2	
3-37	5280300220	VALVE,CHOKE	1	
3-38	99204080031	R-B 99204080030 WASHER	1	
3-39	47601700200	BOARD,BLOW OVER CHECK	1	
3-40	99210050012	WASHER,S,5	2	
3-41	99011050602	SCREW,5X60	2	
3-43	4460650021	FILTER,AIR	1	Includes bolt
3-44	4520650091	COVER,CLEANER,W/BOLT	1	
3-45	3800637C200	BOLT,CLEANER COVER	1	
3-46	4550300290	SET,CARBURETOR	1	
3-50	2230700090	FUEL PIPE ASSY	1	
3-51	68000731201	CLIP 6.3	1	
3-52	6750404280	FILTER,FUEL	1	~C226130 C226131~
3-53	5910300220	TANK,FUEL	1	
3-53	5910301620	TANK,FUEL,WHITE	1	
3-54	5950300290	CAP,TANK (BLACK/RED)	1	
3-55	65900801200	COLLAR	2	
3-58	99463050185	BOLT,HEX 5X18PS	2	
3-61	5600712020	SWIVEL CAP	1	A123651~
3-70	44225143800	PUMP,PRIMING ASS'Y	1	
3-77	7000250408	PIPE,FUEL,2.5x4x80	1	
3-78	7000250407	PIPE,FUEL,2.5x4x70	1	
3-79	53432710200	GROMMET,FUEL PIPE	1	

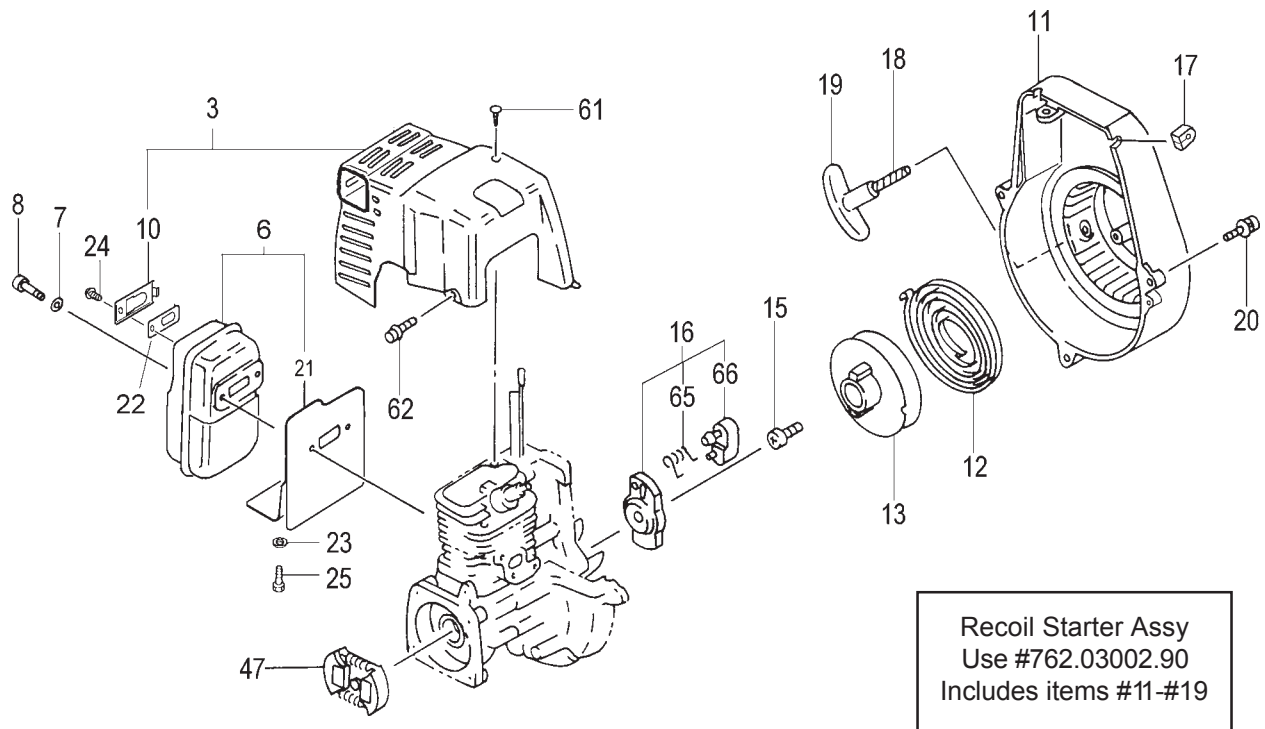

ITEM	PART NUMBER	DESCRIPTION	QTY	COMMENTS
4-3	7380300221	PROTECTOR,MUFFLER	1	
4-6	7040300290	SET,MUFFLER	1	Includes heat shield
4-7	99201060011	WASHER,6	2	
4-8	99053060553	SCREW,HEX.HOLE	2	
4-10	7210440020	PIPE,TAIL	1	~Y210350
4-10	7210300320	PIPE,TAIL	1	Y210351~
4-11	1120300280	CASE,FAN	1	
4-12	78006097200	SPRING,RECOIL	1	
4-13	77406097200	PULLEY,STARTER	1	
4-15	8390201020	SCREW,SET	1	
4-16	79806500900	PULLEY,STARTER,ASS'Y	1	
4-17	20306000200	GROMMET,PRIMARY CORD	1	
4-18	78306097200	ROPE,STARTER	1	
4-19	78506410200	HANDLE,STARTER	1	
4-20	99463040154	BOLT,HEX,4X15,PS	3	
4-21	7350300281	SHIELD,HEAT	1	
4-22	7320440020	ARRESTER,SPARK	1	
4-23	99201050011	WASHER,5	1	
4-24	99435040081	SCREW,4X8PS	1	
4-25	99414050081	SCREW,5X8,S	1	
4-47	2770634F900	R-B 2770634F901 CLUTCH	1	
4-61	99073045104	SCREW,TAPPING,4.5X10	1	
4-62	99425040128	BOLT,PS,4X12	2	
4-65	79006097200	SPRING,STARTER PAWL	1	
4-66	7880650020	PAWL,STARTER	1	

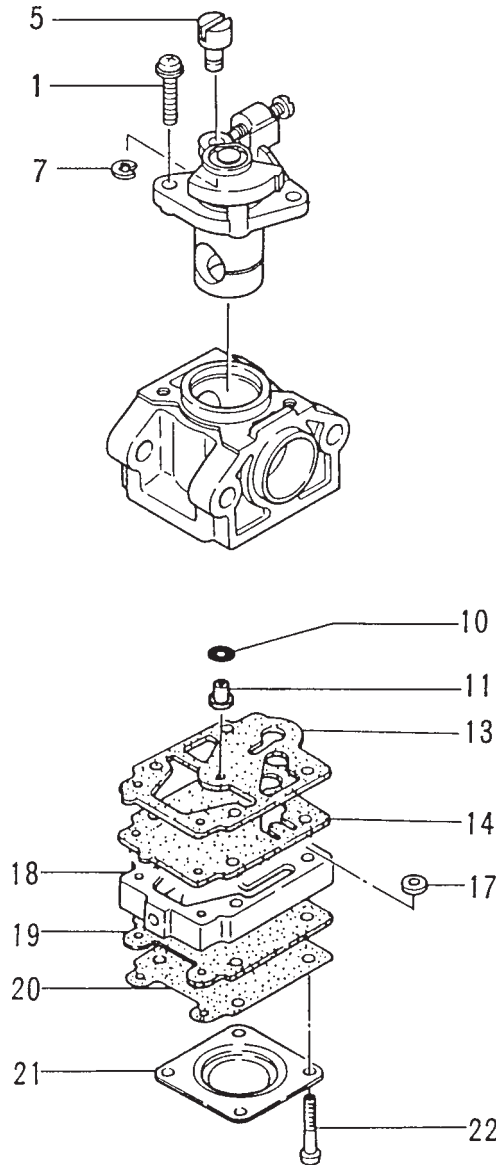

A small retainer (560-02170-20), has been added to this model after serial # A099801 to prevent the barrel end of the throttle wire from coming detached from the carburetor.

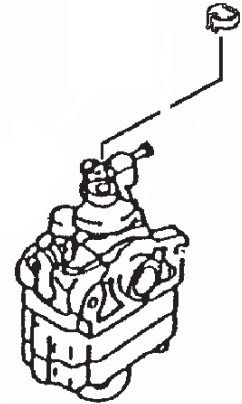

ITEM	PART NUMBER	DESCRIPTION	QTY	COMMENTS
	4550300290	SET, CARBURETOR	1	Includes carburetor gasket
5-1	54825140200	SCREW, THROTTLE SET	2	
5-5	53925120200	SWIVEL	1	Carburetor Repair Kit - 650-25140-900
5-7	48925100200	RING, STOP	1	Gasket/Diaphragm Kit - 652-25140-900
5-10	55025100200	O-RING	1	
5-11	5992001W34	JET, MAIN, #34	1	
5-13	~ ~ ~	GASKET, PUMP	1	~ Contained in Carb Kits
5-14	~ ~ ~	DIAPHRAGM, PUMP	1	
5-17	57825007200	SCREEN, INLET	1	
5-18	5752522580	BODY, PUMP	1	
5-19	~ ~ ~	GASKET, DIAPHRAGM	1	
5-20	~ ~ ~	DIAPHRAGM, METERING	1	
5-21	47625004200	COVER, DIAPHRAGM	1	
5-22	54825101200	SCREW, SET	4	

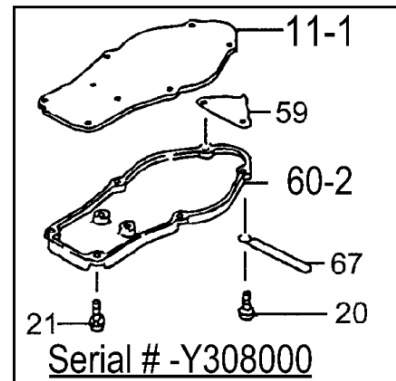
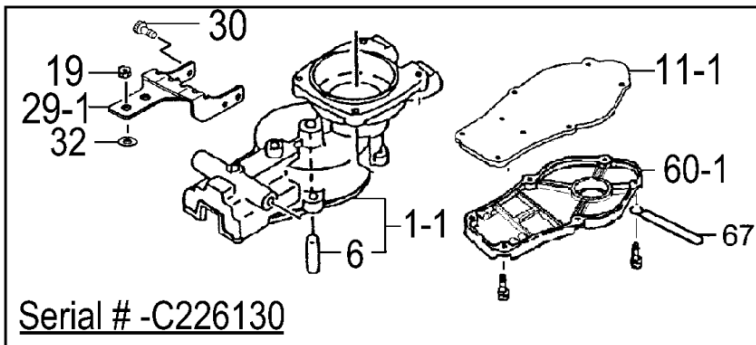
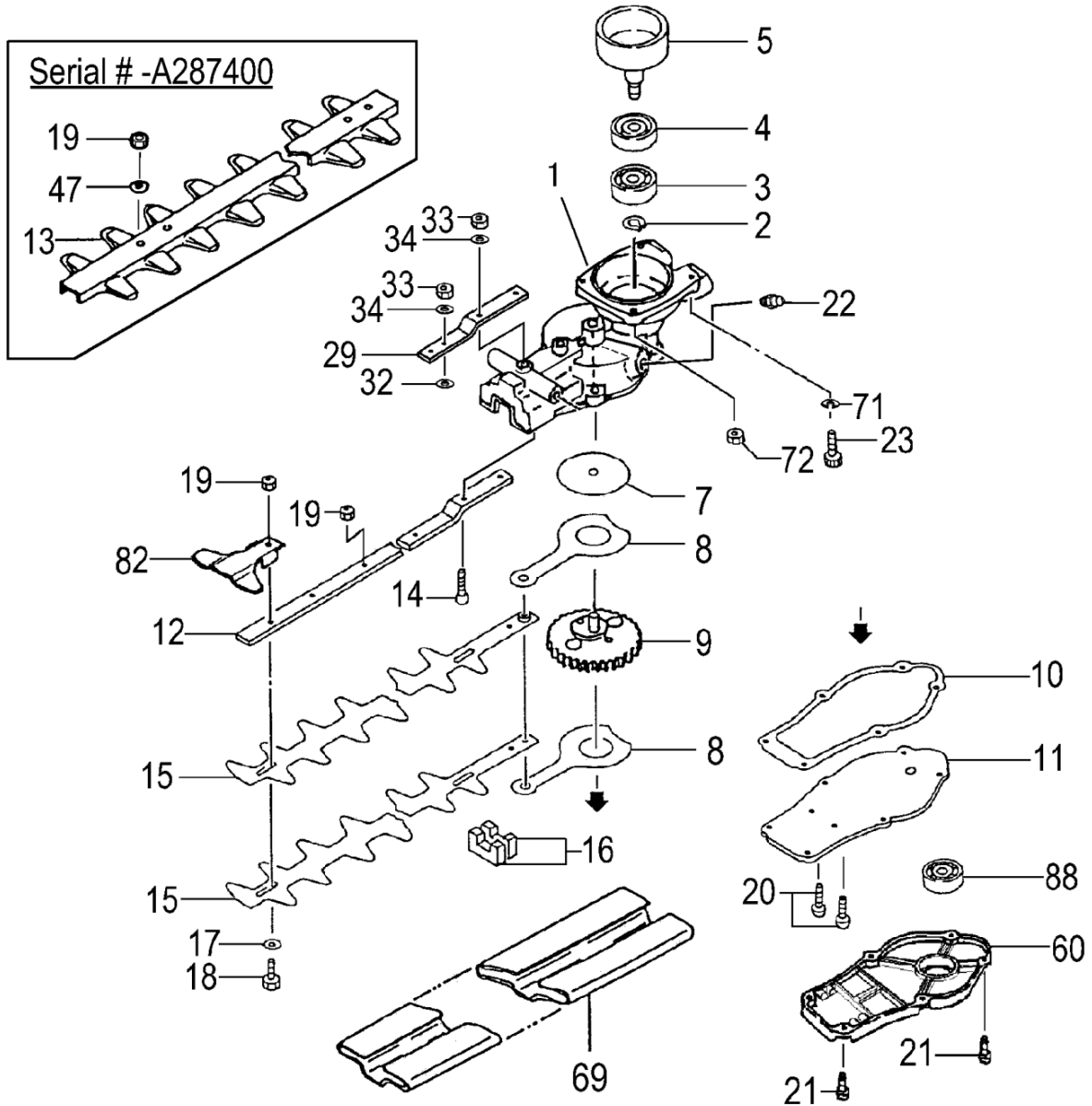

ITEM	PART NUMBER	DESCRIPTION	QTY	COMMENTS
6-1-1	3003316082	CASE,GEAR	1	~C226130
6-1	3003329081	CASE,GEAR	1	C226131~
6-2	99350015002	RING,STOP,C-15 EX	1	
6-3	99961600200	BEARING,BALL,#6002	1	
6-4	99961600202	BEARING,BALL,#6002Z	1	
6-5	2883318080	DRUM,CLUTCH	1	
6-6	30533160200	SHAFT,GEAR	1	~C226130
6-7	07533160200	PLATE,GUIDE	1	
6-8	1013319020	ROD,CAM	2	
6-9	3073318020	GEAR,2	1	~C226130
6-9	2923319480	GEAR 2	1	C226131~
6-10	30333160200	GASKET,GEAR CASE	1	
6-11-1	6303316020	COVER,GEAR CASE	1	~C226130
6-11	6303316520	COVER,GEAR CASE	1	C226131~
6-12	1223319022	BAR,33-1/4"OAL,STANDARD	1	~A287400
6-12	1223319120	BAR,33-1/4"OAL,METRIC	1	A287401~
6-13	1363319020	PLATE,PROTECTION	1	~A287400
6-14	99052060165	BOLT,HEX,6X16	2	~C226130
6-14	99052060255	BOLT,HEX FLUSH,6X25	2	C226131~
6-15	1203319021	BLADE,A,DS,30"	2	
6-16	08533160200	SEAL,GREASE A	2	
6-17	12933202201	WASHER,7	6	
6-18	1243320221	BOLT,CUTTER FIXING,A	6	~A287400
6-18	1243228720	BOLT,FIXING,A,M6	6	A287401~
6-19	1233317A20	NUT,SPECIAL	6	~A287400
6-19	40927	NUT,FLANGE,6	6	~C226130
6-19	40927	NUT,FLANGE,6	5	C226131~
6-20	99461040104	BOLT,HEX,4X10,S	2	
6-21	99461040124	BOLT,HEX,4X12	6	
6-22	30032250801	FITTING,GREASE	1	
6-23	99051060143	BOLT,HEX,6X14	2	~A091000
6-23	99461060184	BOLT,HEX,6x18S	2	A091001~
6-29-1	4623319120	PLATE,SUPPORT	1	~C226130
6-29	4623329020	PLATE,SUPPORT	1	C226131~
6-30	99461040104	BOLT,HEX,4X10,S	4	
6-32	87132600200	WASHER,SPECIAL,B	1	
6-33	99187060001	NUT	3	C226131~
6-34	99201060011	WASHER,6	3	C226131~
6-47	99201060011	WASHER,6	2	Y210351~
6-47	99201060011	WASHER,6	2	~A287400
6-59	2963319020	SPACER	1	~Y308000
6-60-2	3013319120	CASE,GEAR B	1	~Y308000
6-60-1	3013319121	CASE,GEAR B	1	~C226130
6-60	3013316021	CASE,GEAR B	1	C226131~
6-67	19811600800	R-B 19811660800 CLAMP	1	~C226130
6-69	1383319020	COVER,CUTTER,30"	1	
6-71	99210060012	WASHER,S,6	2	~A091000
6-72	99440060011	NUT,SPRING 6	2	
6-82	1353319120	PROTECTOR,BLADE	1	
6-88	99961608013	BEARING,BALL,#608Z	1	C226131~

Units Before
S/N ~C226130

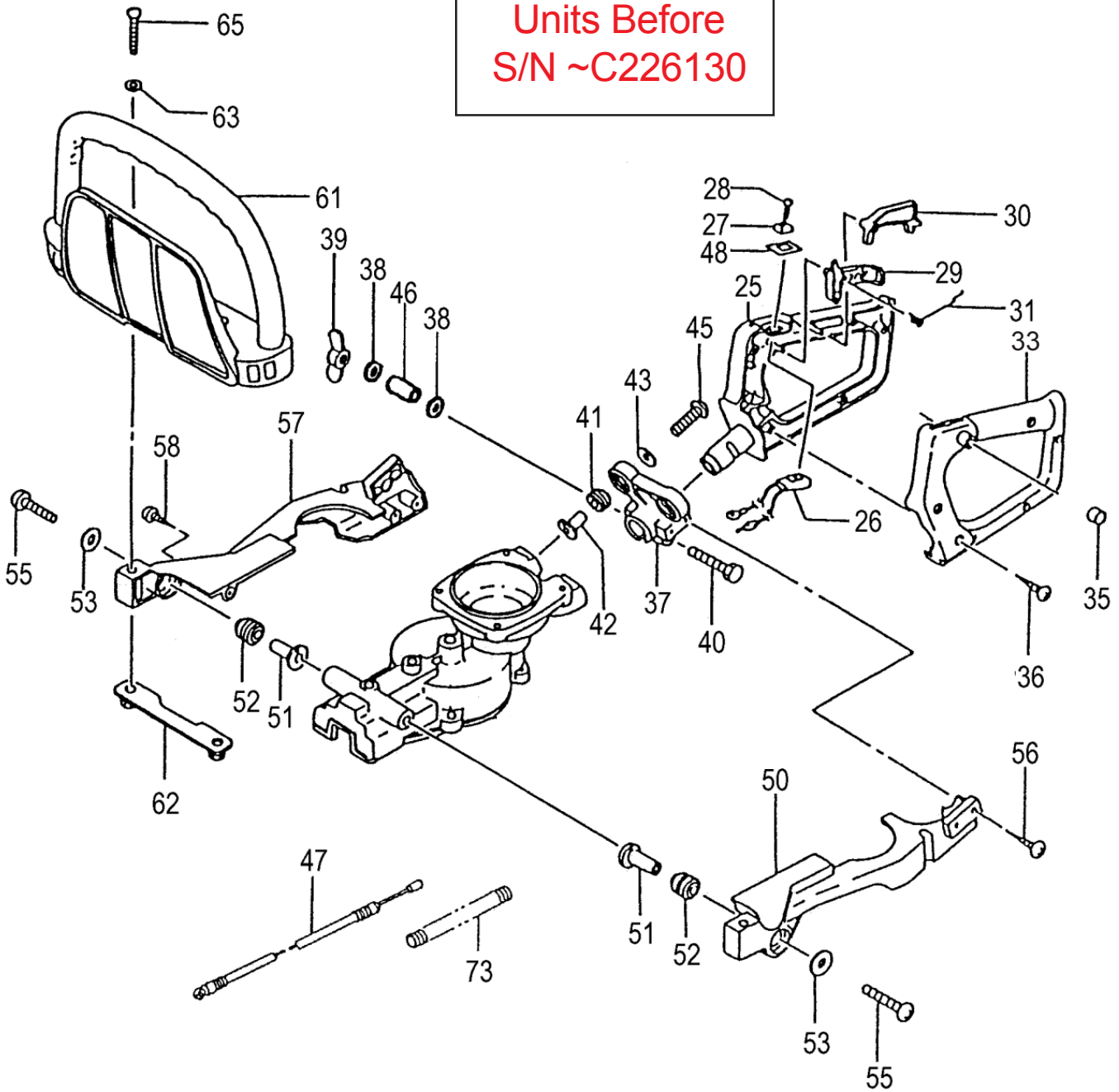

ITEM	PART NUMBER	DESCRIPTION	QTY	COMMENTS
7-25	05033160200	HANDLE,A	1	Units before S/N C226130
7-26	17033160800	SWITCH,STOP	1	
7-27	2581165020	BUTTON,STOP	1	
7-28	99011030101	SCREW,3X10	1	
7-29	23033160200	LEVER,THROTTLE	1	
7-30	23133160200	LEVER,SAFETY	1	
7-31	23233160200	SPRING,THROTTLE LEVER	1	
7-33	05133160200	HANDLE,B	1	
7-35	7653212020	CAP	1	
7-36	99072045164	SCREW,TAPPING,4.5X16	6	
7-37	05833160200	BRACKET,HANDLE	1	
7-38	99200060011	WASHER,SMALL,6	2	
7-39	99161060012	NUT,WING,6	1	
7-40	99021060501	BOLT,6X50	1	
7-41	26632750200	DAMPER,B	2	
7-42	27632710201	COLLAR,DAMPER B	2	
7-43	36832057200	WASHER,BRAKE SHAFT	2	
7-45	99414050301	SCREW,5X30/S	4	
7-46	2943316021	COLLAR 16	1	
7-47	88506500800	WIRE,THROTTLE	1	
7-48	92533160200	DECAL,STOP BUTTON	1	
7-50	2493316020	BODY,CLAMP A	1	
7-51	27632710201	COLLAR,DAMPER B	2	
7-52	26632750200	DAMPER,B	2	
7-53	36832057200	WASHER,BRAKE SHAFT	2	
7-56	99073045124	SCREW,TAPPING,4.5X12	2	
7-57	2503316020	BODY,CLAMP,B	1	
7-58	99073045124	SCREW,TAPPING,4.5X12	1	
7-61	2103316022	HANDLE,FRONT	1	
7-62	0403316080	SUPPORT,HANDLE	1	
7-63	3683205720	WASHER,5	2	
7-65	99414050401	SCREW,5X40/S	2	
7-73	16407007000	TUBE,PROTECTION,7X700	1	

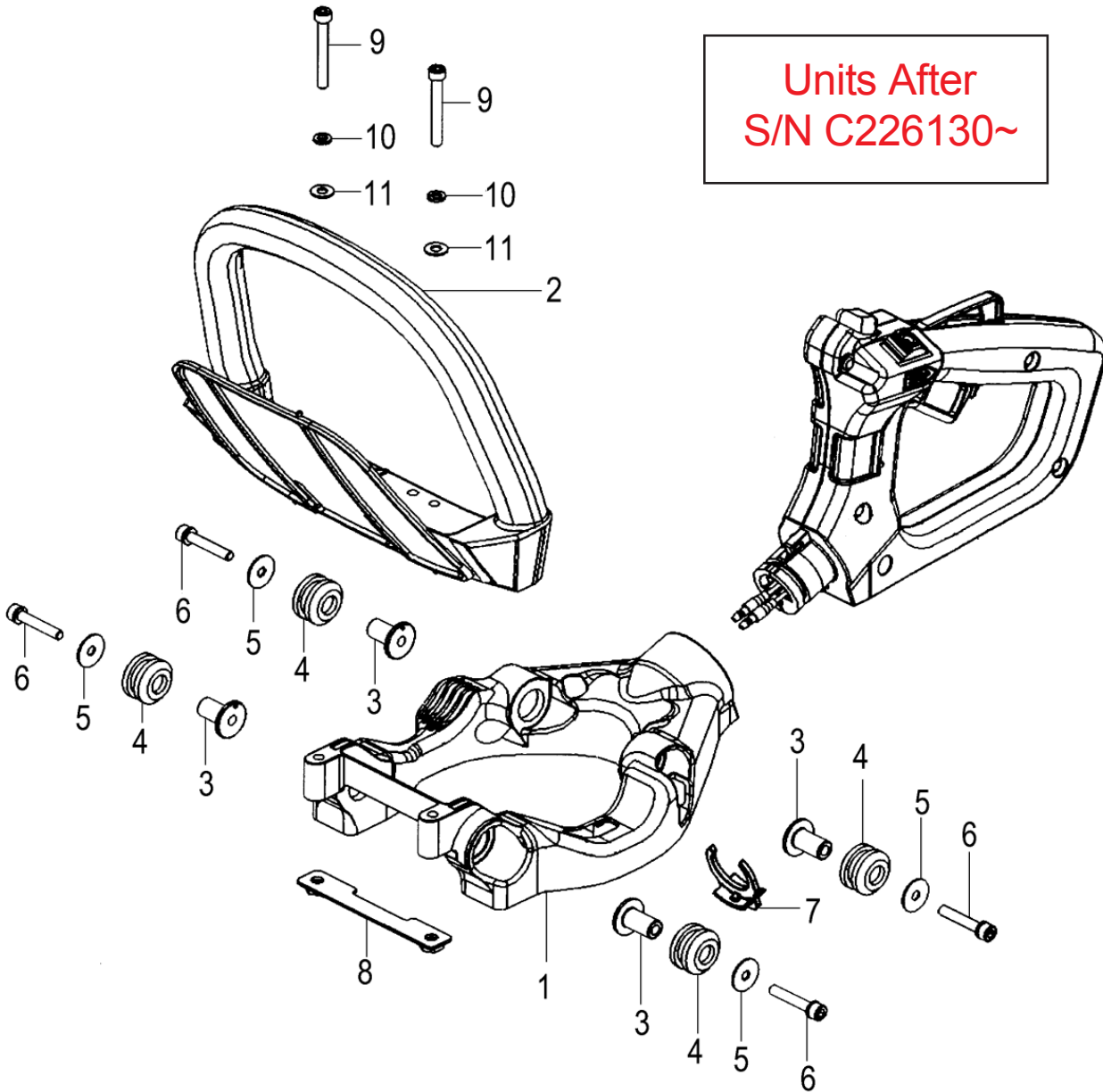

ITEM	PART NUMBER	DESCRIPTION	QTY	COMMENTS
8-1	2603329020	FRAME,HANDLE	1	Units after S/N C226130
8-2	2103316022	HANDLE	1	
8-3	27632710201	COLLAR,DAMPER B	4	
8-4	26632750200	DAMPER,B	4	
8-5	36832057200	WASHER,BRAKE SHAFT	4	
8-6	99461050304	BOLT,HEX,5X30S	4	
8-7	5053319620	CLIP	1	
8-8	0403316080	SUPPORT,HANDLE	1	
8-9	99051050403	BOLT,HEX,5X40	2	
8-10	99210050062	WASHER,S,5	2	
8-11	3683205720	WASHER,5	2	

Units After
S/N C226130~

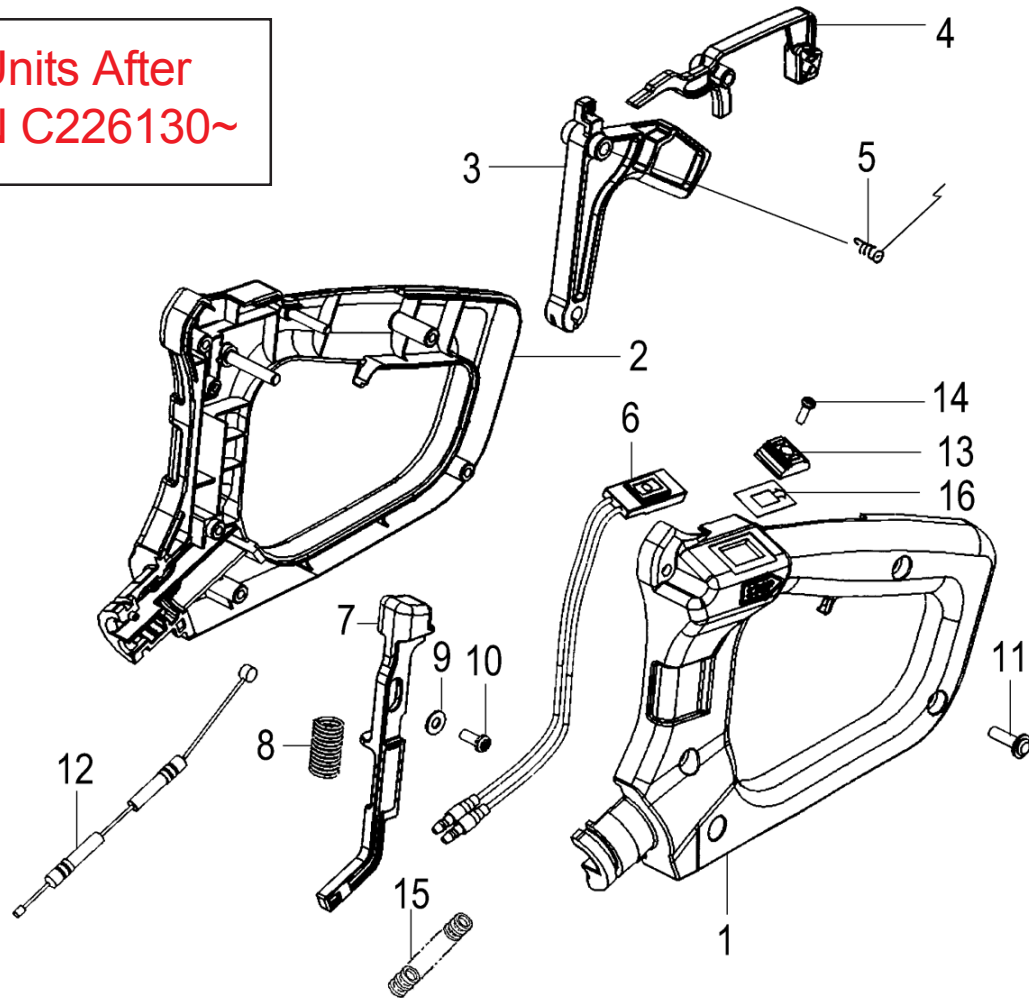

ITEM	PART NUMBER	DESCRIPTION	QTY	COMMENTS
9-1	0513329020	HANDLE,B	1	Units after S/N C226130
9-2	0503329020	HANDLE,A	1	
9-3	2303329020	LEVER,THROTTLE	1	
9-4	2313329020	LEVER,SAFETY	1	
9-5	23233160200	SPRING,THROTTLE LEVER	1	
9-6	1703324780	BUTTON,STOP	1	
9-7	2333329020	LEVER,LOCK	1	
9-8	2453329020	SPRING	1	
9-9	99201040011	WASHER,4	1	
9-10	99341040101	SCREW,TAPPING,4X10	1	
9-11	99072045164	SCREW,TAPPING,4.5X16	5	
9-12	8853324780	WIRE,THROTTLE	1	
9-13	2581165020	BUTTON,STOP	1	
9-14	99431030101	SCREW,3X10	1	
9-15	1640701501	TUBE,PROTECTION,7x150	1	
9-16	92533160200	DECAL,STOP BUTTON	1	

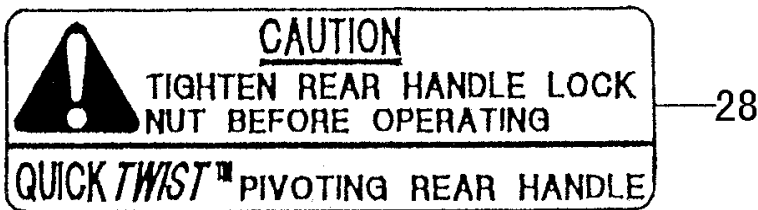
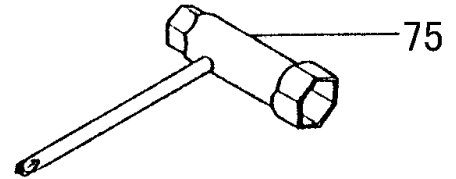
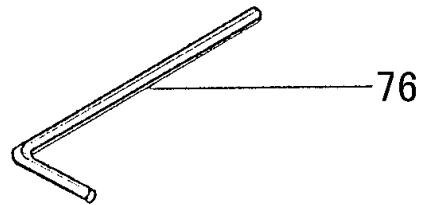
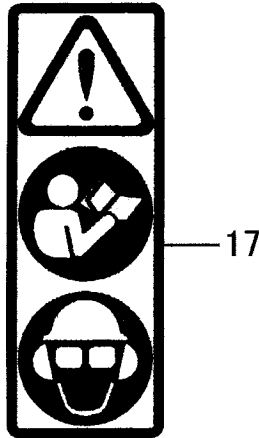
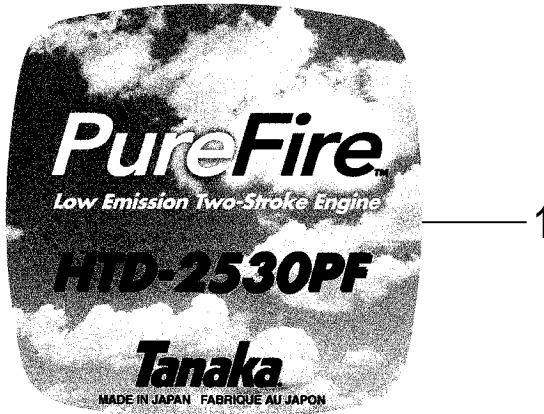

ITEM	PART NUMBER	DESCRIPTION	QTY	COMMENTS
10-1	9060300421	DECAL,MODEL HTD-2530PF	1	
10-17	9203246620	DECAL,CAUTION	1	
10-28	91933160200	DECAL	1	~C226130
10-75	81320000200	WRENCH,HEX,4	1	
10-76	03629331501	SPANNER,COMBI	1	

Date: June 2001

Model & Serial: THT-2100/THT-2120/THT-2510/THT-2520/THT-2540/HTD-2522PF/HTD-2526PF/HTD-2530PF/HTS-2530PF.

All units produced after serial number W100101.

Reason: When these units are fitted with the aluminum safety shield, some experience loosening of the blade jam nuts. A flat washer has been added between the nut and the aluminum shield to help prevent the nut from becoming loose.

Models THT-2100, 2120, 2510 and HTD-2526PF, 2522PF require 3 washers.

Models THT-2520, 2540 and HTS-2530PF and HTD-2530PF require 2 washers

Part Number Changes:

Old Part #	New Part #	Description	Remarks
992-01060-011		Washer	

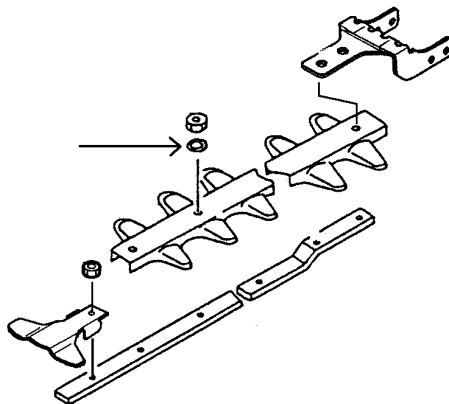

Date: January, 2002

Model & Serial: All THT, HTD, HTS, TPH hedgetrimmer models.

All units after serial number Y004401

Reason: All future production of hedgetrimmer models will utilize a blade-retaining nut that is of the locking variety. These nuts are oblong on one side to prevent loosening during use, but can be removed and re-installed without losing their locking ability.

When adjusting blade-fastening hardware, thread the bolt (18) through the blades and guide bar from the bottom, to a point where the flat washer (17), is still able to rotate, (usually to seat, and then backed off between 1/4 and 1/2 revolution). Then install the lock nuts on the topside, tightening them while holding the bolt in place. Tighten all nuts, and then re-check for adjustment prior to operation. A lubricating agent, such as WD-40 should also be used to prevent sap build-up and premature wear.

Part Number Changes:

Old Part #	New Part #	Description	Remarks
123-33202-200	123-3317A-20	Lock Nut	Reference #19

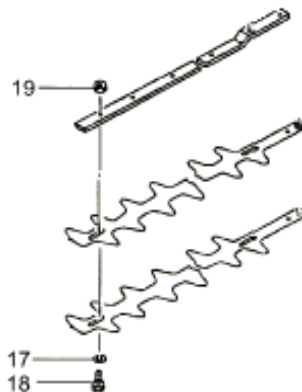

Date: September 2002

Model & Serial: HTD-2522PF / 2526PF / 2530PF / HTS-2530PF

All units after serial number Y210151

Reason: Exhaust gas flow from these models in some circumstances can cause scorching of leaves during cutting due to the direction of the tail pipe outlet.

The direction of flow from the muffler has been re-directed to exit horizontally rather than vertically.

New style components should be ordered via the set listed below when these parts are replaced.

Part Number Changes:

Old Part #	New Part #	Description	Remarks
721-04400-20	721-03003-20	Tail Pipe	
738-03002-20	738-03003-21	Muffler Protector	
	721-03003-00	Muffler Protector Set	Includes Re-Directed Tail Pipe

Tanaka is marketed exclusively by:



Date: December 2004

Model & Serial: **TPH-210/2501/250PF270PF – A290201 and later.**
HTD-2522PF/2526PF/2530PF, HTS-2530PF/2540PF – A302051 and later.
THT-2120/2520/2540 – A302051 and later.

Reason: Configuration standardization of hardware, converting blade hardware from US Standard thread to Metric thread.

Comments: Please verify serial number on unit prior to ordering replacement blade hardware and add the support plate on older serial numbers.

Part Number Changes:

Description	Old parts #	New parts #	Comments
For TPH-210/2501/250PF/270PF			
Cutter guide 625.5L M6	122-32287-21	122-32286-21	
Cutter fixing bolt A	124-33202-21	124-32287-20	4 to 1 pc
Cutter fixing bolt B		125-32287-20	3 pcs
Flange nut M6	123-3317A-20	991-82060-001	4 pcs
For HTD-2522PF			
Cutter guide 625.5L M6	122-33160-21	122-33178-20	
Cutter fixing bolt A	124-33202-21	124-32287-20	
Flange nut M6	123-3317A-20	991-82060-001	
Protection plate 390L	136-33160-20		
Washer 6	992-01060-011		3 pcs
For THT-2120/HTD-2526PF			
Cutter guide 734L M6	122-33168-21	122-33248-20	
Cutter fixing bolt A	124-33202-21	124-32287-20	
Flange nut M6	123-3317A-20	991-82060-001	
Protection plate 390L	136-33160-20		
Washer 6	992-01060-011		3 pcs
For HTS-2530PF			
Cutter guide 830L M6	122-33187-20	122-33285-20	
Cutter fixing bolt A	124-33202-21	124-32287-20	
Flange nut M6	123-3317A-20	991-82060-001	
Protection plate 585L	136-33181-20		
Washer 6	992-01060-011	3 to 1 pc	
For THT-2520/HTD-2530PF			
Cutter guide 845.5L M6	122-33190-22	122-33191-20	
Cutter fixing bolt A	124-33202-21	124-32287-20	
Flange nut M6	123-3317A-20	991-82060-001	
protection plate 380L	136-33190-20		
Washer 6	992-01060-011		2 pcs
For THT-2540/HTS-2540PF			
Cutter guide 1105L M6	122-33185-20	122-33186-20	
Cutter fixing bolt A	124-33202-21	124-32287-20	
Flange nut M6	123-3317A-20	991-82060-001	
Protection plate 585L	136-33181-20		
Washer 6	992-01060-011	3 to 1 pc	