

ELECTRIC TOOL PARTS LIST

■ ROTARY HAMMER Model DH 50MRV

2007 · 9 · 21

(E1)

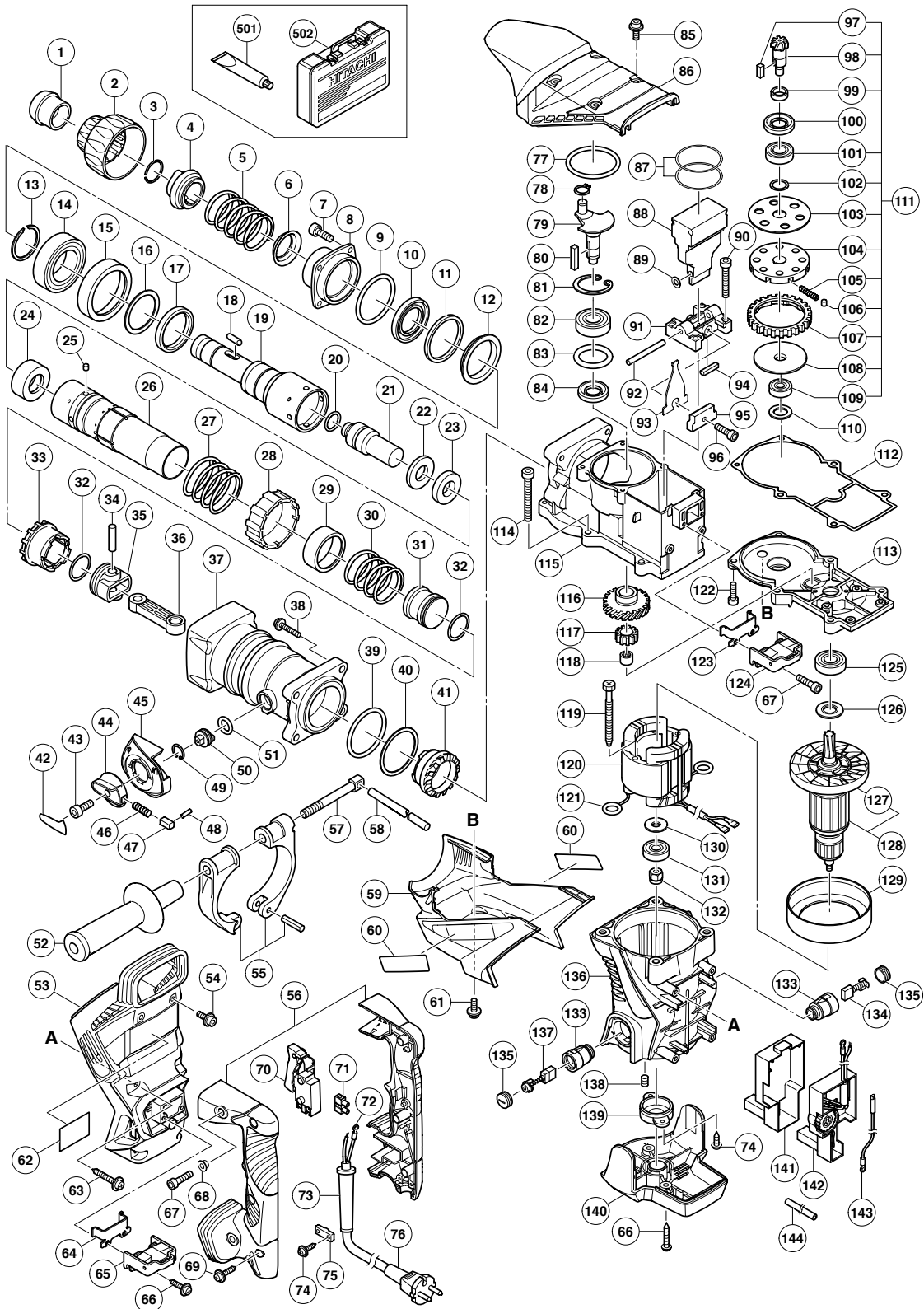

PARTS

DH 50MRY

ITEM NO.	CODE NO.	DESCRIPTION	NO. USED	REMARKS
1	321-306	FRONT CAP	1	
2	328-900	GRIP	1	
3	318-590	STOPPER RING	1	
4	328-899	NEEDLE HOLDER	1	
5	313-419	RETAINER SPRING	1	
6	318-589	SPRING HOLDER	1	
7	985-479	SEAL LOCK HEX. SOCKET HD. BOLT M8X25	4	
8	318-587	FRONT COVER	1	
9	878-863	O-RING (S-70)	1	
10	318-588	OIL SEAL (NBR710)	1	
11	318-586	URETHANE RING	1	
12	318-585	URETHANE RING HOLDER	1	
13	318-582	RETAINING RING D40	1	
14	600-8CM	BALL BEARING 6008CM	1	
15	318-581	SLEEVE	1	
16	328-884	THRUST WASHER (A)	1	
17	328-883	RETAINER DAMPER	1	
18	313-421	NEEDLE ROLLER D8X20	2	
19	328-882	RETAINER SLEEVE	1	
20	986-104	O-RING	1	
21	328-885	SECOND HAMMER	1	
22	328-886	DAMPER WASHER	1	
23	328-887	DAMPER	1	
24	328-888	DAMPER HOLDER	1	
25	328-891	NEEDLE PIN D8X6	4	
26	328-889	CYLINDER	1	
27	328-895	LOCK SPRING	1	
28	318-562	LOCK SLEEVE	1	
29	328-892	SPRING HOLDER (B)	1	
30	328-893	CLUTCH SPRING	1	
31	328-890	STRIKER	1	
32	328-880	O-RING	2	
33	328-894	CLUTCH	1	
34	328-879	PISTON PIN	1	
35	328-877	PISTON	1	
36	328-878	CONNECTING ROD	1	
37	328-896	CYLINDER CASE	1	
38	990-083	HEX. SOCKET HD. BOLT (W/FLANGE) M8X35	4	
39	985-779	O-RING (D)	1	
40	328-897	THRUST WASHER (B)	1	
41	328-898	BEVEL GEAR	1	
42	321-867	LEVER LABEL	1	
43	983-162	SEAL LOCK HEX. SOCKET HD. BOLT M4X12	1	
44	321-309	CHANGE LEVER	1	
45	328-901	LEVER HOLDER	1	
46	321-310	LEVER SPRING	1	
47	321-311	PUSHING BUTTON	1	
48	321-312	PIN D2X10	1	
49	311-229	RETAINING RING FOR D20 HOLE	1	
50	324-934	LEVER SHAFT	1	
51	873-095	O-RING (P-16)	1	

PARTS

DH 50MRY

ITEM NO.	CODE NO.	DESCRIPTION	NO. USED	REMARKS
52	318-574	SIDE HANDLE	1	
53	328-910	BACK COVER	1	
54	998-485	HEX. SOCKET HD. BOLT (W/FLANGE) M5X14	2	
55	318-575	HANDLE HOLDER	1	
56	328-920	HANDLE (A).(B) SET	1	
57	318-576	HANDLE BOLT	1	
58	971-786	STOPPER ROD	1	
59	328-909	HOOD	1	
60		HITACHI LABEL	2	
61	998-471	HEX. SOCKET HD. BOLT (W/FLANGE) M5X12	1	
62		NAME PLATE	1	
63	328-707	TAPPING SCREW (W/FLANGE) D5X30 (BLACK)	4	
64	980-750	GUIDE PLATE	1	
65	980-727	HANDLE RUBBER	1	
66	305-558	TAPPING SCREW (W/FLANGE) D5X25 (BLACK)	4	
67	990-079	SEAL LOCK HEX. SOCKET HD. BOLT M5X16	6	
68	991-711	DISTANCE PIECE (B)	4	
69	307-028	TAPPING SCREW (W/FLANGE) D4X25 (BLACK)	3	
70	990-941	SWITCH (B) (1P SCREW TYPE) W/O LOCK	1	
71	938-307	PILLAR TERMINAL	1	
*	72	980-063	1	TERMINAL
*	72	930-804	1	TERMINAL M4.0 (10 PCS.) FOR GBR (110V), USA, CAN
*	73	953-327	1	CORD ARMOR D8.8
*	73	938-051	1	CORD ARMOR D10.1
	74	984-750	4	TAPPING SCREW (W/FLANGE) D4X16
*	75	960-266	1	CORD CLIP
*	75	981-987Z	1	CORD CLIP FOR SUI
*	76	500-390Z	1	CORD (CORD ARMOR D8.8)
*	76	500-235Z	1	CORD (CORD ARMOR D8.8) FOR INA, IND
*	76	500-408Z	1	CORD (CORD ARMOR D8.8) FOR NZL, AUS
*	76	500-453Z	1	CORD (CORD ARMOR D10.1) FOR USA, CAN
*	76	500-446Z	1	CORD (CORD ARMOR D8.8) FOR GBR (230V)
*	76	500-460Z	1	CORD (CORD ARMOR D10.1) FOR GBR (110V)
*	76	500-391Z	1	CORD (CORD ARMOR D8.8) FOR SUI
*	76	500-457Z	1	CORD (CORD ARMOR D8.8) FOR CHN
*	76	500-435Z	1	CORD (CORD ARMOR D8.8) FOR HKG
	77	877-314	1	CYLINDER O-RING (I.D 69.3)
	78	939-542	1	RETAINING RING FOR D12 SHAFT (10 PCS.)
	79	328-868	1	CRANK SHAFT
	80	328-869	1	FEATHER KEY 3X3X25
	81	948-227	1	RETAINING RING FOR D47 HOLE
	82	620-4DD	1	BALL BEARING 6204DDCMPS2L
	83	985-765	1	O-RING (B)
	84	328-867	1	OIL SEAL
	85	994-192	4	HEX. SOCKET HD. BOLT (W/FLANGE) M5X16
	86	328-908	1	CRANK COVER
	87	878-713	2	CYLINDER O-RING (B)
	88	328-902	1	WEIGHT
	89	957-585	2	WASHER
	90	306-061	4	SEAL LOCK HEX. SOCKET HD. BOLT M5X30
	91	328-903	1	BASE

PARTS

DH 50MRY

ITEM NO.	CODE NO.	DESCRIPTION	NO. USED	REMARKS	
92	328-904	WEIGHT PIN	1		
93	328-905	LEAF SPRING	2		
94	328-907	WEIGHT BUMPER	2		
95	328-906	SPRING HOLDER	2		
96	990-079	SEAL LOCK HEX. SOCKET HD. BOLT M5X16	2		
97	944-109	FEATHER KEY 3X3X8	1		
98	328-873	BEVEL PINION	1		
99	328-874	COLLAR	1		
100	328-867	OIL SEAL	1		
101	620-2DD	BALL BEARING 6202DDCMPS2L	1		
102	313-058	WASHER	1		
103	318-552	WASHER (A)	1		
104	318-554	GEAR HOLDER	1		
105	329-095	SPRING (C)	8		
106	313-057	NEEDLE PIN D6X6	8		
107	328-875	SECOND GEAR	1		
108	328-876	SPACER	1		
109	629-VVM	BALL BEARING 629VVC2PS2L	1		
110	944-525	BEARING WASHER (C)	1		
111	328-872	SLIP CLUTCH ASS'Y	1	INCLUD. 97-99, 101-109	
112	328-881	SEAL PACKING	1		
113	328-916	GEAR COVER	1		
114	986-940	SEAL LOCK HEX. SOCKET HD. BOLT M6X45	4		
115	328-866	CRANK CASE	1		
116	328-870	FIRST GEAR	1		
117	328-871	SECOND PINION	1		
118	939-299	NEEDLE BEARING (M661)	1		
119	953-121	HEX. HD. TAPPING SCREW D5X50	2		
*	120	340-712C	STATOR ASS'Y 110V-115V	1	INCLUD. 121
*	120	340-712G	STATOR ASS'Y 120V	1	INCLUD. 121
*	120	340-712E	STATOR ASS'Y 220V-230V	1	INCLUD. 121
*	120	340-712F	STATOR ASS'Y 240V	1	INCLUD. 121
121	958-032	BRUSH TERMINAL	2		
122	321-313	SEAL LOCK HEX. SOCKET HD. BOLT M6X22	2		
123	980-750	GUIDE PLATE	1		
124	980-727	HANDLE RUBBER	1		
125	620-2DD	BALL BEARING 6202DDCMPS2L	1		
126	980-700	DUST WASHER (B)	1		
127	318-918	FAN	1		
*	128	360-819C	ARMATURE ASS'Y 110V-115V	1	INCLUD. 127
*	128	360-819U	ARMATURE ASS'Y 120V	1	INCLUD. 125-127, 130, 131
*	128	360-819E	ARMATURE ASS'Y 220V-230V	1	INCLUD. 127
*	128	360-819F	ARMATURE ASS'Y 240V	1	INCLUD. 127
129	328-917	FAN GUIDE	1		
130	944-954	BEARING WASHER	1		
131	620-1VV	BALL BEARING 6201VVCMP2L	1		
132	301-797	MAGNET	1		
133	980-487	BRUSH HOLDER	2		
134	999-044	CARBON BRUSH (1 PAIR)	1		
135	940-540	BRUSH CAP	2		
136	328-915	HOUSING ASS'Y	1	INCLUD. 133, 138	

PARTS

DH 50MRY

ITEM NO.	CODE NO.	DESCRIPTION	NO. USED	REMARKS
137	999-074	CARBON BRUSH (AUTO STOP TYPE) (1 PAIR)	1	
138	938-477	HEX. SOCKET SET SCREW M5X8	2	
139	328-918	BEARING HOLDER	1	
140	328-919	TAIL COVER	1	
141	328-914	CASE (B)	1	
* 142	328-911	CONTROLLER CIRCUIT 110V-115V	1	
* 142	328-912	CONTROLLER CIRCUIT 120V	1	
* 142	328-913	CONTROLLER CIRCUIT 220V-240V	1	
* 143	317-113	INTERNAL WIRE	1	EXCEPT FOR USA, CAN
144	326-541	VINYL TUBE (I.D.9.5XT0.56X85)	1	

STANDARD ACCESSORIES

ITEM NO.	CODE NO.	DESCRIPTION	NO. USED	REMARKS
501	981-840	GREASE (A) FOR HAMMER. HAMMER DRILL (30G)	1	
502	328-921	CASE (PLASTIC)	1	

OPTIONAL ACCESSORIES

ITEM NO.	CODE NO.	DESCRIPTION	NO. USED	REMARKS
601	308-471	GREASE FOR HAMMER. HAMMER DRILL (70G)	1	
602	980-927	GREASE FOR HAMMER. HAMMER DRILL (500G)	1	
603	320-859	SYRINGE (BLOW-OUT BULB TYPE)	1	
604	318-085	SYRINGE (BELLOWS TYPE)	1	
605	313-448	DRILL BIT (SDS MAX) D16X340	1	
606	313-456	DRILL BIT (SDS MAX) D16X540	1	
607	313-449	DRILL BIT (SDS MAX) D19X340	1	
608	313-457	DRILL BIT (SDS MAX) D19X540	1	
609	313-450	DRILL BIT (SDS MAX) D22X320	1	
610	313-458	DRILL BIT (SDS MAX) D22X520	1	
611	313-451	DRILL BIT (SDS MAX) D25X320	1	
612	313-459	DRILL BIT (SDS MAX) D25X520	1	
613	313-452	DRILL BIT (SDS MAX) D28X370	1	
614	313-460	DRILL BIT (SDS MAX) D28X570	1	
615	313-453	DRILL BIT (SDS MAX) D32X370	1	
616	313-461	DRILL BIT (SDS MAX) D32X570	1	
617	313-454	DRILL BIT (SDS MAX) D38X370	1	
618	313-462	DRILL BIT (SDS MAX) D38X570	1	
619	313-455	DRILL BIT (SDS MAX) D40X370	1	
620	313-463	DRILL BIT (SDS MAX) D40X570	1	
621	944-460	TAPER SHANK DRILL BIT D11X100	1	

OPTIONAL ACCESSORIES

DH 50MRY

ITEM NO.	CODE NO.	DESCRIPTION	NO. USED	REMARKS
622	944-461	TAPER SHANK DRILL BIT D12.3X110	1	
623	993-038	TAPER SHANK DRILL BIT D12.7X110	1	
624	944-462	TAPER SHANK DRILL BIT D14.3X110	1	
625	944-500	TAPER SHANK DRILL BIT D14.5X110	1	
626	944-463	TAPER SHANK DRILL BIT D17.5X120	1	
627	313-464	TAPER SHANK ADAPTER ASS'Y (SDS MAX) NO. 1	1	INCLUD. 628
628	944-477	COTTER	1	
629	313-465	ADAPTER (SDS MAX) FOR SDS PLUS SHANK BIT	1	
630	955-994	CORE BIT 25MM	1	
631	955-995	CORE BIT 29MM	1	
632	955-996	CORE BIT 32MM	1	INCLUD. 633
633	955-997	GUIDE PLATE (FOR CORE BIT 32MM)	1	
634	955-998	CORE BIT 35MM	1	INCLUD. 635
635	955-999	GUIDE PLATE (FOR CORE BIT 35MM)	1	
636	956-000	CORE BIT 38MM	1	INCLUD. 637
637	956-001	GUIDE PLATE (FOR CORE BIT 38MM)	1	
638	955-154	CORE BIT 45MM	1	INCLUD. 639
639	955-166	GUIDE PLATE (FOR CORE BIT 45MM)	1	
640	955-155	CORE BIT 54MM	1	INCLUD. 641
641	955-167	GUIDE PLATE (FOR CORE BIT 54MM)	1	
642	956-002	CORE BIT 64MM	1	INCLUD. 643
643	956-003	GUIDE PLATE (FOR CORE BIT 64MM)	1	
644	955-157	CORE BIT 79MM	1	INCLUD. 645
645	955-168	GUIDE PLATE (FOR CORE BIT 79MM)	1	
646	956-004	CORE BIT 94MM	1	INCLUD. 647
647	956-005	GUIDE PLATE (FOR CORE BIT 94MM)	1	
648	955-159	CORE BIT 105MM	1	INCLUD. 649
649	955-169	GUIDE PLATE (FOR CORE BIT 105MM)	1	
650	956-006	CORE BIT 120MM	1	INCLUD. 651
651	956-007	GUIDE PLATE (FOR CORE BIT 120MM)	1	
652	956-728	CORE BIT 150MM	1	INCLUD. 653
653	956-743	GUIDE PLATE (FOR CORE BIT 150MM)	1	
654	313-466	CORE BIT SHANK (B) SDS MAX D25-35	1	
655	313-467	CORE BIT SHANK (A) SDS MAX D38-150	1	
656	956-009	CENTER PIN (B) 147L FOR CORE BIT D32-35	1	
657	955-165	CENTER PIN (A) 133L FOR CORE BIT D38-150	1	
658	321-813	DRILL CHUCK 13VLD-D	1	
659	313-468	CHUCK ADAPTER (SDS MAX)	1	
660	303-334	CHUCK HANDLE	1	
661	930-515	CHUCK WRENCH 10G	1	
662	313-469	CHEMICAL ANCHOR ADAPTER (SDS MAX) 12.7MM	1	
663	313-470	CHEMICAL ANCHOR ADAPTER (SDS MAX) 19MM	1	
664	313-471	BULL POINT (SDS MAX) 280L	1	
665	313-472	BULL POINT (SDS MAX) 400L	1	
666	313-473	COLD CHISEL (SDS MAX) 280MM	1	
667	313-474	COLD CHISEL (SDS MAX) 400MM	1	
668	313-475	CUTTER (SDS MAX) W50X400L	1	
669	313-476	SCOOP (SDS MAX) 400L	1	
670	313-478	RAMMER (SDS MAX) 150MM X 150MM	1	
671	313-477	BUSHING TOOL (SDS MAX)	1	
672	313-479	SHANK (SDS MAX) FOR RAMMER, BUSHING TOOL	1	