

# HITACHI

## INSTRUCTION MANUAL AND SAFETY INSTRUCTIONS FOR ROTARY HAMMER

### MODEL DH 24PE

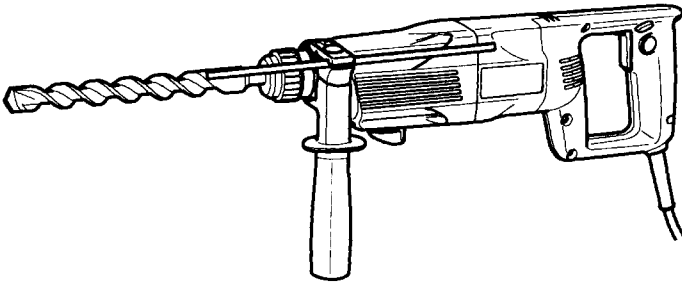

**⚠ WARNING:**

Improper and unsafe use of this power tool can result in death or serious bodily injury!

This manual contains important information about product safety. Please read and understand this manual before operating the power tool. Please keep this manual available for others before they use the power tool.



**DOUBLE INSULATION**

# — CONTENTS —

	Page
IMPORTANT INFORMATION .....	3
MEANINGS OF SIGNAL WORDS .....	3
<b>SAFETY</b> .....	4
GENERAL SAFETY RULES .....	4
SPECIFIC SAFETY RULES AND SYMBOLS .....	7
DOUBLE INSULATION FOR SAFER OPERATION .....	8
<b>FUNCTIONAL DESCRIPTION</b> .....	9
NAME OF PARTS .....	9
SPECIFICATIONS .....	9
<b>ASSEMBLY AND OPERATION</b> .....	10
APPLICATIONS .....	10
PRIOR TO OPERATION .....	10
HOW TO USE .....	12
HOW TO USE THE CORE BIT (FOR LIGHT LOAD) .....	15
<b>MAINTENANCE AND INSPECTION</b> .....	17
<b>ACCESSORIES</b> .....	18
STANDARD ACCESSORIES .....	18
OPTIONAL ACCESSORIES .....	18

---

## **IMPORTANT INFORMATION**

---

Read and understand all of the operating instructions, safety precautions and warnings in the Instruction Manual before operating or maintaining this power tool.

Most accidents that result from power tool operation and maintenance are caused by the failure to observe basic safety rules or precautions. An accident can often be avoided by recognizing a potentially hazardous situation before it occurs, and by observing appropriate safety procedures.

Basic safety precautions are outlined in the "SAFETY" section of this Instruction Manual and in the sections which contain the operation and maintenance instructions.

Hazards that must be avoided to prevent bodily injury or machine damage are identified by WARNINGS on the power tool and in this Instruction Manual.

Never use this power tool in a manner that has not been specifically recommended by HITACHI, unless you first confirm that the planned use will be safe for you and others.

---

## **MEANINGS OF SIGNAL WORDS**

---

**WARNING** indicates a potentially hazardous situations which, if ignored, could result in serious personal injury.

**CAUTION** indicates a hazardous situations which, if ignored, could result in moderate personal injury, or could cause machine damage.

**NOTE** emphasizes essential information.

---

## GENERAL SAFETY RULES

---

**⚠ WARNING:** Read and understand all instructions.

Failure to follow all instructions listed below, may result in electric shock, fire and/or serious personal injury.

### SAVE THESE INSTRUCTIONS

#### 1. Work Area

- (1) **Keep your work area clean and well lit.** Cluttered benches and dark areas invite accidents.
- (2) **Do not operate power tools in explosive atmospheres, such as in the presence of flammable liquids, gases, or dust.** Power tools create sparks which may ignite the dust or fumes.
- (3) **Keep bystanders, children, and visitors away while operating a power tool.** Distractions can cause you to lose control.

#### 2. Electrical Safety

- (1) **Double Insulated tools are equipped with a polarized plug (one blade is wider than the other.) This plug will fit in a polarized outlet only one way. If the plug does not fit fully in the outlet, reverse the plug. If it still does not fit, contact a qualified electrician to install a polarized outlet. Do not change the plug in any way.** Double Insulation  eliminates the need for the three wire grounded power cord and grounded power supply system.
- (2) **Avoid body contact with grounded surfaces such as pipes, radiators, ranges and refrigerators.** There is an increased risk of electric shock if your body is grounded.
- (3) **Don't expose power tools to rain or wet conditions.** Water entering a power tool will increase the risk of electric shock.
- (4) **Do not abuse the cord. Never use the cord to carry the tools or pull the plug from a receptacle. Keep cord away from heat, oil, sharp edges or moving parts. Replace damaged cords immediately.** Damaged cords increase the risk of electric shock.
- (5) **When operating a power tool outside, use an outdoor extension cord marked "W-A" or "W".** These cords are rated for outdoor use and reduce the risk of electric shock.

#### 3. Personal Safety

- (1) **Stay alert, watch what you are doing and use common sense when operating a power tool. Do not use tool while tired or under the influence of drugs, alcohol, or medication.** A moment of inattention while operating power tools may result in serious personal injury.

- (2) **Dress properly. Do not wear loose clothing or jewelry. Contain long hair. Keep your hair, clothing, and gloves away from moving parts.** Loose clothes, jewelry, or long hair can be caught in moving parts.
- (3) **Avoid accidental starting. Be sure switch is off before plugging in.** Carrying tools with your finger on the switch or plugging in tools that have the switch on invites accidents.
- (4) **Remove adjusting keys or switches before turning the tool on.** A wrench or a key that is left attached to a rotating part of the tool may result in personal injury.
- (5) **Do not overreach. Keep proper footing and balance at all times.** Proper footing and balance enables better control of the tool in unexpected situations.
- (6) **Use safety equipment. Always wear protective glasses.** Dust mask, non-skid safety shoes, hard hat, or ear plugs must be used for appropriate conditions.

#### 4. Tool Use and Care

- (1) **Use clamps or other practical way to secure and support the workpiece to a stable platform.** Holding the work by hand or against your body is unstable and may lead to lose of control.
- (2) **Do not force tool. Use the correct tool for your application.** The correct tool will do the job better and safer at the rate for which it is designed.
- (3) **Do not use tool if switch does not turn it on or off.** Any tool that cannot be controlled with the switch is dangerous and must be repaired.
- (4) **Disconnect the plug from the power source before making any adjustments, changing accessories, or storing the tool.** Such preventive safety measures reduce the risk of starting the tool accidentally.
- (5) **Store idle tools out of reach of children and other untrained persons.** Tools are dangerous in the hand of untrained users.
- (6) **Maintain tools with care. Keep cutting tools sharp and clean.** Properly maintained tools, with sharp cutting edges are less likely to bind and are easier to control.
- (7) **Check for misalignment or binding of moving parts, breakage of parts, and any other condition that may affect the tools operation. If damaged, have the tool serviced before using.** Many accidents are caused by poorly maintained tools.
- (8) **Use only accessories that are recommended by the manufacturer for your model.** Accessories that may be suitable for one tool, may become hazardous when used on another tool.

#### 5. Service

- (1) **Tool service must be performed only by qualified repair personnel.** Service or maintenance performed by unqualified personnel could result in a risk of injury.

**(2) When servicing a tool, use only genuine Hitachi replacement parts. Follow instructions in the Maintenance section of this manual.** Use of unauthorized parts or failure to follow Maintenance Instruction may create a risk of electric shock or injury.

**6. Never touch moving parts.**

Never place your hands, fingers or other body parts near the tool's moving parts.

**7. Never operate without all guards in place.**

Never operate this tool without all guards or safety features in place and in proper working order. If maintenance or servicing requires the removal of a guard or safety feature, be sure to replace the guard or safety feature before resuming operation of the tool.

**8. Use right tool.**

Don't force small tool or attachment to do the job of a heavy-duty tool.

Don't use tool for purpose not intended — for example — don't use circular saw for cutting tree limbs or logs.

**9. Never use a power tool for applications other than those specified.**

Never use a power tool for applications other than those specified in the Instruction Manual.

**10. Handle tool correctly.**

Operate the tool according to the instructions provided herein. Do not drop or throw the tool. Never allow the tool to be operated by children, individuals unfamiliar with its operation or unauthorized personnel.

**11. Keep all screws, bolts and covers tightly in place.**

Keep all screws, bolts, and plates tightly mounted. Check their condition periodically.

**12. Do not use power tools if the plastic housing or handle is cracked.**

Cracks in the tool's housing or handle can lead to electric shock. Such tools should not be used until repaired.

**13. Blades and accessories must be securely mounted to the tool.**

Prevent potential injuries to yourself or others. Blades, cutting implements and accessories which have been mounted to the tool should be secure and tight.

**14. Keep motor air vent clean.**

The tool's motor air vent must be kept clean so that air can freely flow at all times. Check for dust build-up frequently.

**15. Operate power tools at the rated voltage.**

Operate the power tool at voltages specified on its nameplate.

If using the power tool at a higher voltage than the rated voltage, it will result in abnormally fast motor revolution and may damage the unit and the motor may burn out.

**16. Never use a tool which is defective or operating abnormally.**

If the tool appears to be operating unusually, making strange noises, or otherwise appears defective, stop using it immediately and arrange for repairs by a Hitachi authorized service center.

**17. Never leave tool running unattended. Turn power off.**

Don't leave tool until it comes to a complete stop.

**18. Carefully handle power tools.**

Should a power tool be dropped or struck against hard materials inadvertently, it may be deformed, cracked, or damaged.

**19. Do not wipe plastic parts with solvent.**

Solvents such as gasolie, thinner, benzine, carbon tetrachloride, and alcohol may damage and crack plastic parts. Do not wipe them with such solvents.

Wipe plastic parts with a soft cloth lightly dampened with soapy water and dry thoroughly.

---

## **SPECIFIC SAFETY RULES AND SYMBOLS**

---

1. Hold tools by insulated gripping surfaces when performing an operation where the cutting tool may contact hidden wiring or its own cord. Contact with a "live" wire will make exposed metal parts of the tool "live" and shock the operator.
2. Wear ear plugs when using the tool for extended periods. Prolonged exposure to high intensity noise can cause hearing loss.
3. NEVER touch the tool bit with bare hands after operation.
4. NEVER wear gloves made of stuff liable to roll up such as cotton, wool, cloth or string, etc.
5. ALWAYS attach the side handle and securely grip the Rotary Hammer.
6. ALWAYS be careful with buried object such as an underground wiring.  
Touching these active wiring or electric cable with this tool, you may receive an electric shock.  
Comfirm if there are any buried object such as electric cable within the wall, floor or ceiling where you are going to operate here after.
7. Definitions for symbols used on this tool
  - V ... volts
  - Hz ... hertz
  - A ... amperes
  - no ... no load speed
  - W ... watt
  -  ... Class II Construction
  - /min ... revolutions per minute

---

## **DOUBLE INSULATION FOR SAFER OPERATION**

---

To ensure safer operation of this power tool, HITACHI has adopted a double insulation design. "Double insulation" means that two physically separated insulation systems have been used to insulate the electrically conductive materials connected to the power supply from the outer frame handled by the operator. Therefore, either the symbol "⊞" or the words and "Double insulation" appear on the power tool or on the nameplate.

Although this system has no external grounding, you must still follow the normal electrical safety precautions given in this Instruction Manual, including not using the power tool in wet environments.

To keep the double insulation system effective, follow these precautions:

- Only HITACHI AUTHORIZED SERVICE CENTER should disassemble or assemble this power tool, and only genuine HITACHI replacement parts should be installed.
- Clean the exterior of the power tool only with a soft cloth moistened with soapy water, and dry thoroughly.

Never use solvents, gasoline or thinners on plastic components; otherwise the plastic may dissolve.

**SAVE THESE INSTRUCTIONS  
AND  
MAKE THEM AVAILABLE TO  
OTHER USERS OF THIS TOOL!**



# FUNCTIONAL

**NOTE:**

The information contained in this Instruction Manual is designed to assist you in the safe operation and maintenance of the power tool.

Some illustrations in this Instruction Manual may show details or attachments that differ from those on your own power tool.

## NAME OF PARTS

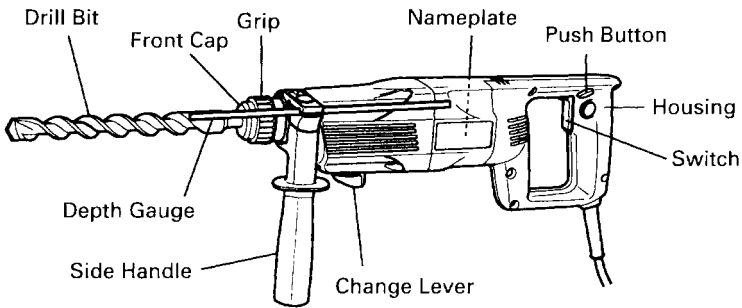

Fig. 1

## SPECIFICATIONS

Motor	Single-Phase, Series Commutator Motor
Power Source	Single-Phase, 115V 60Hz
Current	5.7A
Capacity	Concrete: 1/8" ~ 15/16" (3.4mm ~ 24mm) Steel: 1/2" (13mm) Wood: 1-1/4" (32mm)
No-Load Speed	0 – 1050/min.
Full-load Impact Rate	4400/min.
Weight	5.1 lbs (2.3 kg)

# ASSEMBLY AND OPERATION

---

## APPLICATIONS

---

Rotation and striking function

- Drilling anchor holes
- Drilling holes in concrete
- Drilling holes in tile

Rotation only function

- Drilling in steel or wood (with optional accessories).
- Tightening machine screws, wood screws (with optional accessories).

---

## PRIOR TO OPERATION

---

### 1. Power source

Ensure that the power source to be utilized conforms to the power source requirements specified on the product nameplate.

### 2. Power switch

Ensure that the switch is in the OFF position. If the plug is connected to a receptacle while the switch is in the ON position, the power tool will start operating immediately and can cause serious injury.

### 3. Extension cord

When the work area is far away from the power source, use an extension cord of sufficient thickness and rated capacity. The extension cord should be kept as short as practicable.

** WARNING: Damaged cord must be replaced or repaired.**

### 4. Check the receptacle

If the receptacle only loosely accepts the plug, the receptacle must be repaired. Contact a licensed electrician to make appropriate repairs.

If such a faulty receptacle is used, it may cause overheating, resulting in a serious hazard.

### 5. Confirming condition of the environment:

Confirm that the work site is placed under appropriate conditions conforming to prescribed precautions.

## 6. Mounting the drill bit (Fig. 2)

- (1) To attach a drill bit (SDS-plus shank), fully pull the grip in the direction of the arrow as shown in Fig. 2 and insert the drill bit as far as it will go while manually turning.
- (2) By releasing the grip, the drill bit will be secured.
- (3) To remove the drill bit, fully pull the grip in the direction of the arrow and pull out the drill bit.

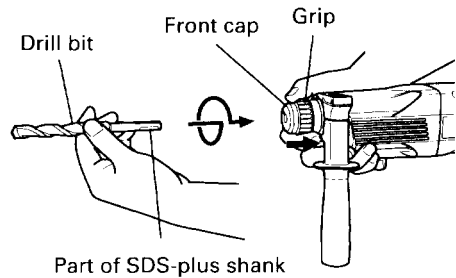

Fig. 2

## 7. Installation of dust cup or dust collector (B) (Optional accessories) (Fig. 3, Fig. 4)

When using a rotary hammer for upward drilling operations attach a dust cup or dust collector (B) to collect dust or particles for easy operation.

### ○ Installing the dust cup

Use the dust cup by attaching to the drill bit as shown in Fig. 3.

When using a bit which has big diameter, enlarge the center hole of the dust cup with this rotary hammer.

### ○ Installing dust collector (B)

When using dust collector (B), insert dust collector (B) from the tip of the bit by aligning it to the groove on the grip (Fig. 4)

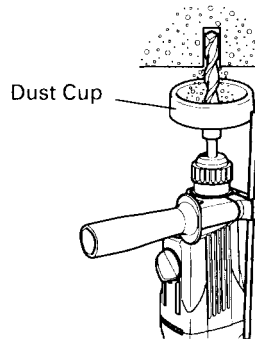

Fig. 3

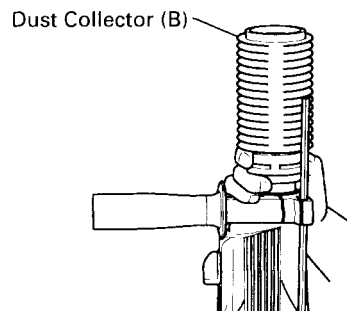

Fig. 4

## ⚠ CAUTION:

- The dust cup and dust collector (B) are for exclusive use of concrete drilling work. Do not use them for wood or metal drilling work.
- Insert dust collector (B) completely into the chuck part of the main unit.
- When turning the rotary hammer on while dust collector (B) is detached from a concrete surface, dust collector (B) will rotate together with the drill bit. Make sure to turn on the switch after pressing dust cup on the concrete surface. (When using dust collector (B) attached to a drill bit that has more than 7-15/32" (190 mm) of overall length, dust collector (B) cannot touch the concrete surface and will rotate. Therefore please use dust collector (B) by attaching to

drill bits which have 6-17/32" (166 mm), 6-19/64" (160 mm) and 4-21/64" (110 mm) overall length.

- Dump particles after every two or three holes when drilling.
- Please replace the drill bit after removing dust collector (B).

## 8. Selecting the driver bit

Screw heads or bits will be damaged unless a bit appropriate for the screw diameter is employed to drive in the screws.

## 9. Confirm the direction of bit rotation (Fig. 5)

The bit rotates clockwise (viewed from the rear side) by pushing the R-side of the reversing switch lever. The L-side of the push button is pushed to turn the bit counterclockwise.

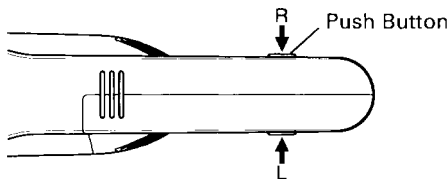

Fig. 5

## HOW TO USE

### ⚠ CAUTION:

- To prevent accidents, make sure to turn the switch off and disconnect the plug from the receptacle when the drill pits and other various parts are installed or removed. The power switch should also be turned off during a work break and after work.

## 1. Switch operation

The rotation speed of the drill bit can be controlled steplessly by varying the amount that the trigger switch is pulled. Speed is low when the trigger switch is pulled slightly and increases as the switch is pulled more. To turn the switch OFF, release the trigger switch to its original position.

## 2. Rotation + Striking

This rotary hammer can be set to rotation and striking mode by turning the change lever fully counterclockwise to **T** mark. (Fig. 6)

- (1) Mount the drill bit.
- (2) Pull the trigger switch after applying the drill bit tip to the drilling position (Fig. 7)
- (3) Pushing the rotary hammer forcibly is not necessary at all. Pushing slightly so that drill dust comes out gradually is just sufficient.

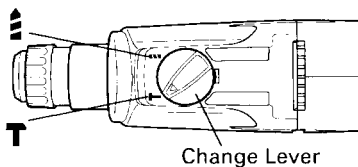

Fig. 6

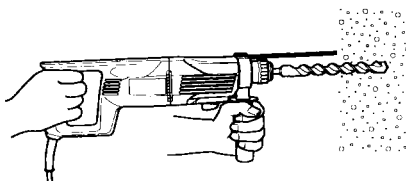



Fig. 7

**⚠ CAUTION:**

- **When the drill bit touches an iron reinforcing rod, the bit will stop immediately and the rotary hammer will react to revolve. Therefore please grip the side handle and handle tightly as shown in Fig. 7.**

**3. Rotation only**

The rotary hammer can be set to rotation only mode by rotating the change lever fully clockwise to  mark. (Fig. 8)  
To drill a wood or metal material using the separately sold drill chuck and chuck adaptor, proceed as follows. Installing drill chuck and chuck adaptor (Fig. 9):

- (1) Attach the drill chuck to the chuck adaptor.
- (2) The part of the SDS-plus shank is the same as the drill bit. Therefore, refer to the item of "Mounting the drill bit" for attaching it.

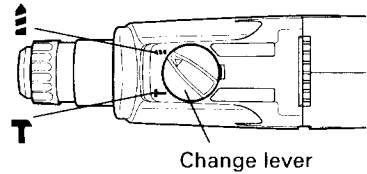

Fig. 8

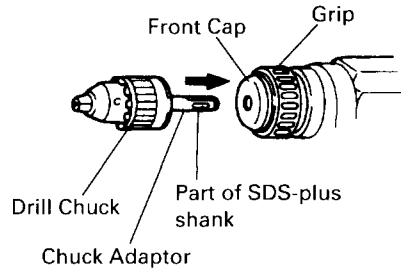

Fig. 9

**⚠ CAUTION:**

- **Application of force more than necessary will not only reducing drilling efficiency at all, but will deteriorate the tip edge of the drill bit and reduce the service life of the rotary hammer in addition.**
- **Drill bit may snap off while withdrawing the rotary hammer from the drilled hole. For withdrawing, it is important to use a pushing motion.**
- **Do not attempt to drill anchor holes or holes in concrete with the main unit in the rotation only function.**
- **Do not attempt to use the rotary hammer in the rotation and striking function with the drill chuck and chuck adaptor attached. This would seriously shorten the service life of every components of the machine.**

**4. When driving machine screws (Fig. 10)**

First, insert the bit into the socket in the end of chuck adaptor (D).  
Next, mount chuck adaptor (D) on the main unit using procedures described in 5 (1), (2), (3), put the tip of the bit in the slots in the head of the screw, grasp the main unit and tighten the screw.

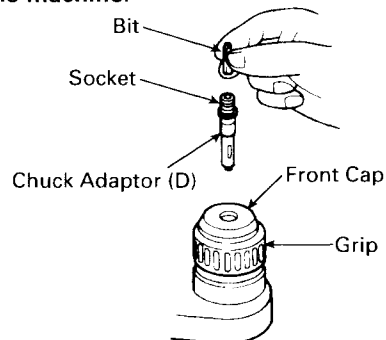

Fig. 10

**⚠ CAUTION:**

- Exercise care not to excessively prolong driving time, otherwise, the screws may be damaged by excessive force.
- Apply the rotary hammer perpendicularly to the screw head when driving a screw; otherwise, the screw head or bit will be damaged, or driving force will not be fully transferred to the screw.
- Do not attempt to use the rotary hammer in the rotation and striking function with chuck adaptor (D) and bit attached.

5. When driving wood screws (Fig. 10)

(1) Selecting a suitable driver bit

Employ phillips screws, if possible, since the driver bit easily slips off the heads of slotted-head screws.

(2) Driving in wood screws

- Prior to driving in wood screws, make pilot holes suitable for them in the wooden board. Apply the bit to the screw head grooves and gently drive the screws into the holes.
- After rotating the rotary hammer at low speed for a while until a wood screw is partly driven into the wood, squeeze the trigger more strongly to obtain the optimum driving force.

**⚠ CAUTION:**

- Exercise care in preparing a pilot hole suitable for the wood screw taking the hardness of the wood into consideration. Should the hole be excessively small or shallow, requiring much power to drive the screw into it, the thread of the wood screw may sometimes be damaged.

6. Using depth gauge (Fig. 11)

- (1) Loosen the knob on the side handle, and insert the depth gauge into the mounting hole on the side handle.
- (2) Adjust the depth gauge position according to the depth of the hole and tighten the knob bolt securely.

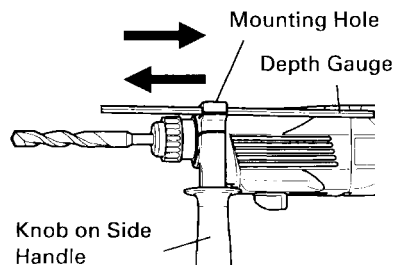

Fig. 11

## 7. How to use the drill bit (taper shank) and the taper shank adaptor.

- (1) Mount the taper shank adaptor to the rotary hammer. (Fig. 12)
- (2) Mount the drill bit (taper shank) to the taper shank adaptor. (Fig. 12)
- (3) Turn the switch ON, and drill a hole in prescribed depth.
- (4) To remove the drill bit (taper shank), insert the cotter into the slot of the taper shank adaptor and strike the head of the cotter with a hammer supporting on the rests. (Fig. 13)

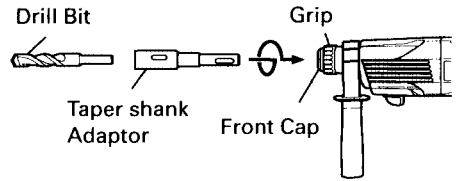

Fig. 12

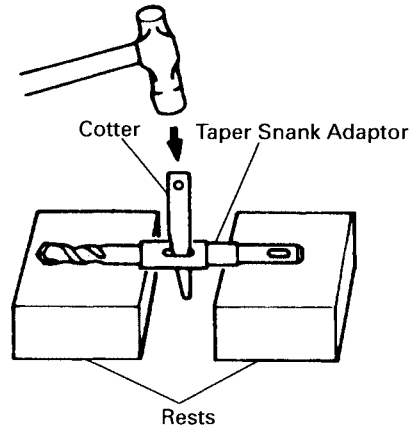

Fig. 13

---

## HOW TO USE THE CORE BIT (FOR LIGHT LOAD)

---

When boring penetrating large hole use the core bit (for light load). At that time use with the center pin and the core bit shank provided as optional accessories.

### 1. Mounting

#### **⚠ CAUTION:**

- Be sure to turn power OFF and disconnect the plug from the receptacle.

- (1) Mount the core bit to the core bit shank. (Fig. 14)

Lubricate the thread of the core bit shank to facilitate disassembly.

- (2) Mount the core bit shank to the rotary hammer. (Fig. 15)

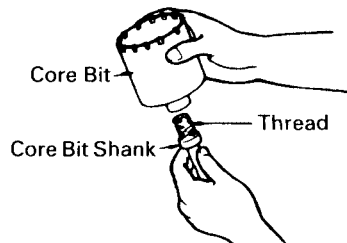

Fig. 14

- (3) Insert the center pin into the guide plate until it stops.
- (4) Engage the guide plate with the core bit, and turn the guide plate to left or right so that it does not fall even if it faces downward. (Fig. 16)

## 2. How to bore (Fig. 17)

- (1) Connect the plug to the power source.
- (2) A spring is installed in the center pin. Push it lightly to the wall or the floor straight. Connect all over the surface of the core bit tip and start operating.
- (3) When boring about 3/16" (5 mm) in depth the position of the hole will establish. Bore after that removing the center pin and the guide plate from core bit.
- (4) Application of excessive force will not only expedite the work, but will deteriorate the tip edge of the drill bit, resulting in reduced service life of the rotary hammer.

### **⚠ CAUTION:**

- **When removing the center pin and the guide plate, turn OFF the switch and disconnect the plug from the receptacle.**

## 3. Dismounting. (Fig. 18)

Remove the core bit shank from the rotary hammer and strike the head of the core bit shank strongly two or three times with the hammer holding the core bit, then the thread becomes loose and the core bit can be removed.

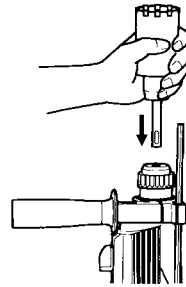

Fig. 15

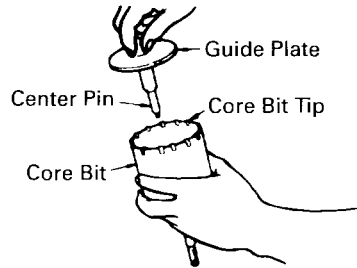

Fig. 16

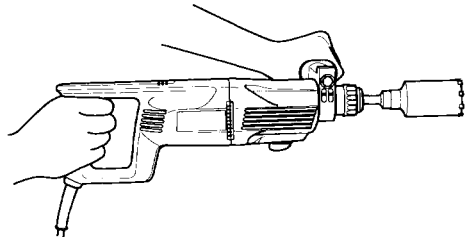

Fig. 17

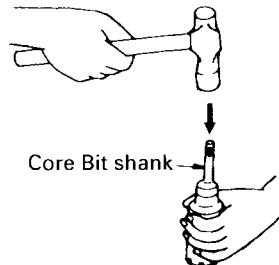

Fig. 18



# MAINTENANCE AND INSPECTION

**⚠ WARNING:** Be sure to switch power OFF and disconnect the plug from the receptacle during maintenance and inspection.

## 1. Inspecting the drill bits

Since use of a dull tool will cause motor malfunctioning and degraded efficiency, replace the drill bit with a new one or resharpening without delay when abrasion is noted.

## 2. Inspecting the mounting screws

Regularly inspect all mounting screws and ensure that they are properly tightened. Should any of the screws be loosened, retighten them immediately.

**⚠ WARNING:** Using this rotary hammer with loosen screws is extremely dangerous.

## 3. Maintenance of the motor

The motor unit winding is the very “heart” of the power tool. Exercise due care to ensure the winding does not become damaged and/or wet with oil or water.

## 4. Inspecting the carbon brushes

For your continued safety and electrical shock protection, carbon brush inspection and replacement on this tool should ONLY be performed by a HITACHI AUTHORIZED SERVICE CENTER.

## 5. How to replace grease

Low viscosity grease is applied to this rotary hammer so that it can be used for a long period without replacing the grease. Please contact the nearest service center for grease replacement when any grease is leaking from loosened screw. Further use of the rotary hammer despite the grease shortage causes malfunction to reduce the service life.

**⚠ CAUTION:** A special grease is used with this machine, therefore, the normal performance of the machine may be badly affected by use of other grease. Please be sure to let one of our service centers undertake replacement of the grease.

## 6. Service and repairs

All quality power tools will eventually require servicing or replacement of parts because of wear from normal use. To assure that only authorized replacement parts will be used, all service and repairs must be performed by a HITACHI AUTHORIZED SERVICE CENTER, ONLY.

# ACCESSORIES

**⚠ WARNING:** Accessories for this power tool are mentioned in this Instruction Manual.

The use of any other attachment or accessory can be dangerous and could cause injury or mechanical damage.

**NOTE:**

Accessories are subject to change without any obligation on the part of the HITACHI.

## STANDARD ACCESSORIES

- (1) Case (Molded plastic) (Code No. 307786) ..... 1
- (2) Side Handle (Code No. 303659) ..... 1
- (3) Depth Gauge (Code No. 303709) ..... 1

## OPTIONAL ACCESSORIES ..... sold separately

### 1. Drilling anchor holes (Rotation + Striking)

- Drill Bit (Slender shaft)

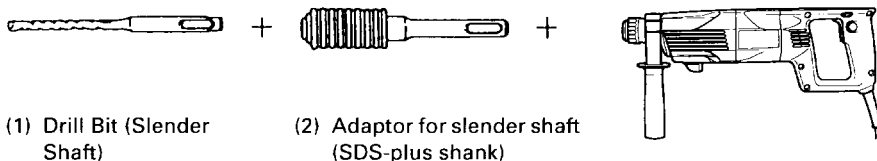

(1) Drill Bit (Slender Shaft)				(2) Adaptor for Slender Shaft
Outer diameter	Effective Length	Overall Length	Code No.	Code No.
1/8" (3.4mm)	1-25/32" (45mm)	3-35/64" (90mm)	306369	306370
9/64" (3.5mm)	1-25/32" (45mm)	3-35/64" (90mm)	306368	

- Drill Bit (Taper shank) and taper shank adaptor

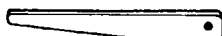
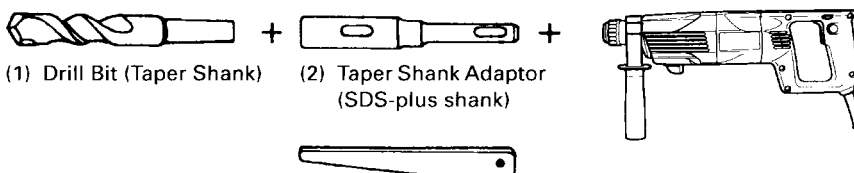

Cotter (Code No. 944477)

External dia.	Code No.
7/16" (11 mm)	944460
31/64" (12.3 mm)	944461
1/2" (12.7 mm)	993038
9/16" (14.3 mm)	944462
73/128" (14.5 mm)	944500
11/16" (17.5 mm)	944463
27/32" (21.5 mm)	944464

Taper mode	Code No.	Applicable drill bit	
Morse taper (No. 1)	303617	Drill bit (Taper shank)	7/16" (11 mm)
			31/64" (12.3 mm)
			1/2" (12.7 mm)
			9/16" (14.3 mm)
			73/128" (14.5 mm)
11/16" (17.5 mm)			
Morse taper (No. 2)	303618	Drill bit (Taper shank)	27/32" (21.5 mm)
A-taper	303619	Taper shank adaptor formed A-taper or B-taper is provided as an optional accessory, but drill bit for it is not provided.	
B-taper	303620		

○ 1/2" (13 mm) Hammer Drill chuck and Chuck wrench

For drilling operations when using a straight shank bit for impact drilling with a hammer drill

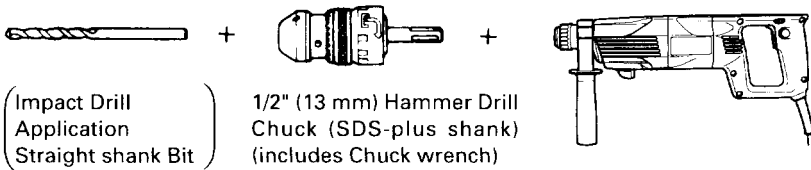

Name	Code No.	Chuck wrench
1/2" (13 mm) Hammer Drill Chuck	303332	
Chuck wrench	303334	
Rubber Cap	303335	

2. Knock-in anchor (Rotation + Striking)

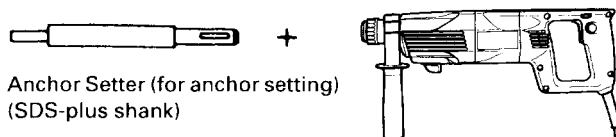

<Outer wedge type with the female screw>

Anchor size	W 1/4" (6.3 mm)	W 5/16" (8 mm)	W 3/8" (9.5 mm)	
Overall Length	10-15/64" (260 mm)	10-15/64" (260 mm)	6-19/64" (160 mm)	10-15/64" (260 mm)
Code No.	302976	302975	303621	302974

<Inner wedge type with the headless screw>

Anchor size	W 1/4" (6.3 mm)	W 5/16" (8 mm)	W 3/8" (9.5 mm)	
Overall Length	10-15/64" (260 mm)	10-15/64" (260 mm)	6-19/64" (160 mm)	10-15/64" (260 mm)
Code No.	302979	302978	303622	302977

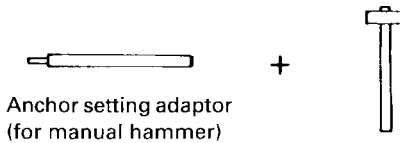

<Outer wedge type with the female screw>

Anchor size	Code No.
W1/4" (6.3 mm)	971794
W5/16" (8 mm)	971795
W3/8" (9.5 mm)	971796
W1/2" (12.7 mm)	971797
W5/8" (15.9 mm)	971798

<Inner wedge type with the headless screw>

Anchor size	Code No.
W1/4" (6.3 mm)	971799
W5/16" (8 mm)	971800
W3/8" (9.5 mm)	971801
W1/2" (12.7 mm)	971802
W5/8" (15.9 mm)	971803

3. Large hole boring (Rotation + Striking)

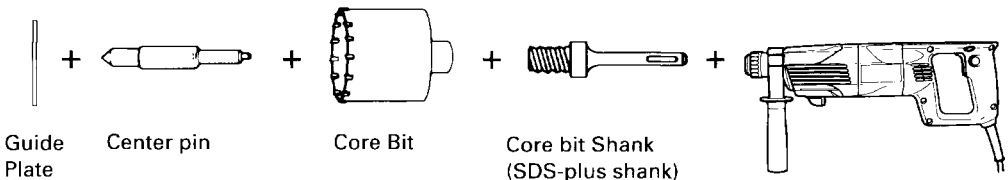

Center pin	Code No.	Core bit (outer diameter)		Code No.	Core bit shank	Code No.	
-	-	(A)	63/64"(25 mm)	982672	Overall length	303625	
			1-9/64" (29 mm)	982673			4-1/8"
(A)	982684		1-1/4" (32 mm)	982674	(105 mm)		
			1-3/8" (35 mm)	982675	11-13/18"		
			1-1/2" (38 mm)	982676	(300 mm)		
(B)	982685	(B)	1-25/32" (45 mm)	982677	(B)	11-13/18"	303627
			1-31/32" (50 mm)	982678		(300 mm)	

### Guide plate

Core bit (outer diameter)	Code No.	Core bit (outer diameter)	Code No.
1-1/4" (32 mm)	982686	1-25/32" (45 mm)	982689
1-3/8" (35 mm)	982687	1-31/32" (50 mm)	982690
1-1/2" (38 mm)	982688		

### 4. Crushing operation (rotation + striking)

Bull point (Round type only)  
(SDS-plus shank)  
Code No. 303046



+

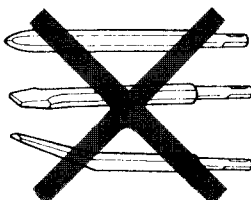
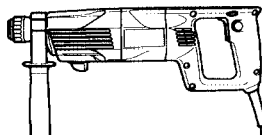

### 5. Bolt placing operation with Chemical Anchor. (rotation + striking)



+



+

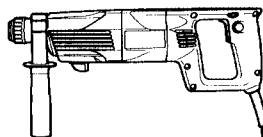

(Standard socket  
on the market)

(SDS-plus shank)  
1/2" (12.7 mm) Chemical  
Anchor Adapter  
(Code No.303044)  
3/4" (19 mm) Chemical  
Anchor Adapter  
(Code No. 303045)

6. Drilling holes and driving screws (rotation only)

- Drill chuck, chuck adaptor and chuck wrench

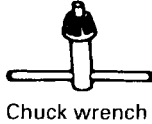
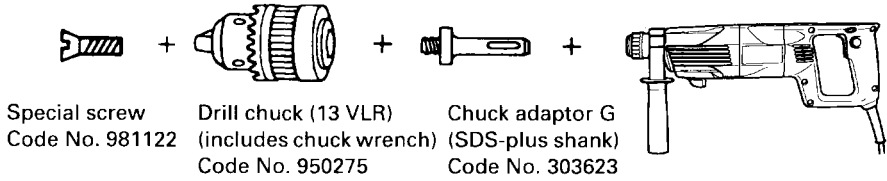

7. Drilling holes (rotation only)

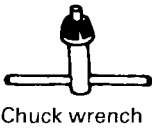
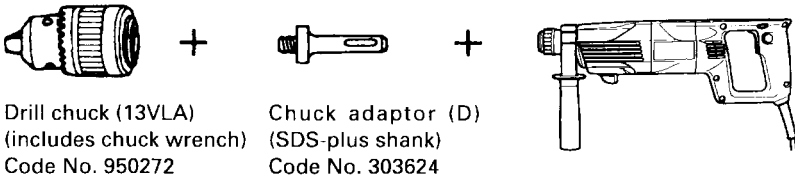

- 1/2" (13 mm) drill chuck ass'y (includes chuck wrench) and chuck (for drilling into steel or wood).

8. Driving Screws (rotation only)

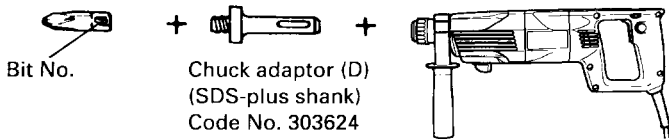

Phillips Driver Bit

Bit No.	Screw Size	Length	Code No.
No.2	1/8" ~ 3/16" (3 – 5 mm)	31/32" (25 mm)	971511Z
No.3	1/4" ~ 5/16" (6 – 8 mm)	31/32" (25 mm)	971512Z

9. Dust cup, Dust collector (B)



Dust cup  
Code No. 971787

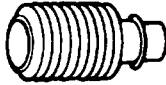

Dust collector (B)  
Code No. 306885

10. Hammer grease A

1.1 lbs (500 g) (in a can) Code No. 980927

0.15 lbs (70 g) (in a green tube) Code No. 308471

0.07 lbs (30 g) (in a green tube) Code No. 981840

**NOTE:**

Specifications are subject to change without any obligation on the part of the HITACHI.

# **Hitachi Koki Co., Ltd.**

Nippon Bldg., 6-2, Ohtemachi 2-chome,  
Chiyoda-ku, Tokyo 100, Japan

706  
Code No. C99082961 N  
Printed in Japan