



HITACHI

ROTARY HAMMER

MODEL DH 22VD

INSTRUCTION MANUAL

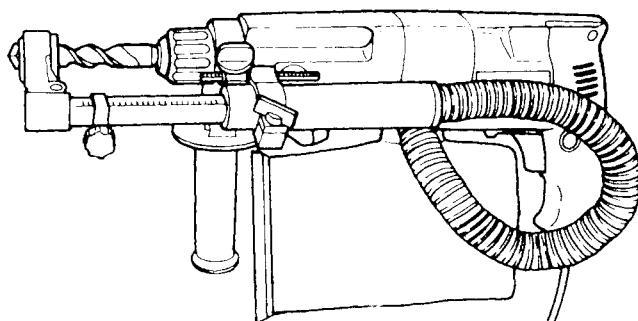

Note :

Before using this Electric Power Tool, carefully read through this INSTRUCTION MANUAL to ensure efficient, safe operation. It is recommended that this MANUAL be kept readily available as an important reference when using this electric power tool.



DOUBLE INSULATION

We sincerely thank you for selecting a HITACHI ELECTRIC POWER TOOL. To operate this electric power tool safely and efficiently, please read this INSTRUCTION MANUAL carefully to get a good understanding of the precautions in operation, capacity of the electric power tool, use and the like.

IMPORTANT INFORMATION: SAFETY RULES FOR POWER TOOLS

WARNING: When using electric tools, basic safety precautions should always be followed to reduce the risk of fire, electric shock, and personal injury, including the following.

READ ALL INSTRUCTIONS

- 1. KEEP WORK AREA CLEAN.** Cluttered areas and benches invite injuries.
- 2. CONSIDER WORK AREA ENVIRONMENT.**
 - Don't expose power tools to rain.
 - Don't use power tools in damp or wet locations.
 - Keep work area well lit.
 - Don't use tool in presence of flammable liquids or gases.
 - Power tools produce sparks during operation. They also spark when switching ON/OFF. Never use power tools in dangerous sites containing lacquer, paint, benzine, thinner, gasoline, gases, adhesive agents, and other materials which are combustible or explosive.
- 3. GUARD AGAINST ELECTRIC SHOCK.** Prevent body contact with grounded surfaces. For example; pipes, radiators, ranges, refrigerator enclosures.
- 4. KEEP CHILDREN AWAY.** Do not let visitors contact tool or extension cord. All visitors should be kept away from work area.
- 5. STORE IDLE TOOLS.** When not in use, tools should be stored in dry, and high or locked-up place-out of reach of children.
- 6. DON'T FORCE TOOL.** It will do the job better and safer at the rate for which it was intended.
- 7. USE RIGHT TOOL.** Don't force small tool or attachment to do the job of a heavy-duty tool. Don't use tool for purpose not intended-for example-don't use circular saw for cutting tree limbs or logs.
- 8. DRESS PROPERLY.** Do not wear loose clothing or jewelry. They can be caught in moving parts.
 - Rubber gloves and non-skid footwear are recommended when working outdoors.
 - Wear protective hair covering to contain long hair.
- 9. USE SAFETY GLASSES.** Also use face or dust mask if cutting operation is dusty.
 - All persons in the area where power tools are being operated should also wear safety eye protectors and face or dust masks.
- 10. DON'T ABUSE CORD.** Never carry tool by cord or yank it to disconnect from receptacle. Keep cord from heat, oil and sharp edges.

- 11. SECURE WORK.** Use clamps or a vise to hold work. It's safer than using your hand and it frees both hands to operate tool.
- 12. DON'T OVERREACH.** Keep proper footing and balance at all times.
- 13. MAINTAIN TOOLS WITH CARE.** Keep tools sharp and clean for better and safer performance.
Follow instructions for lubricating and changing accessories.
Inspect tool cords periodically and if damaged, have repaired by authorized service facility.
Inspect extension cords periodically and replace if damaged.
Keep handles dry, clean, and free from oil and grease.
- 14. DISCONNECT TOOLS.** When not in use, before servicing, and when changing accessories, such as blades, bits, cutters.
- 15. REMOVE ADJUSTING KEYS AND WRENCHES.** Form habit of checking to see that keys and adjusting wrenches are removed from tool before turning it on.
- 16. AVOID UNINTENTIONAL STARTING.** Don't carry plugged-in tool with finger on switch. Be sure switch is off when plugging in.
- 17. OUTDOOR USE EXTENSION CORDS.** When tool is used outdoors, use only extension cords intended for use outdoors and so marked.
- 18. STAY ALERT.** Watch what you are doing. Use common sense. Do not operate tool when you are tired.
- 19. CHECK DAMAGED PARTS.** Before further use of the tool, a guard or other part that is damaged should be carefully checked to determine that it will operate properly and perform its intended function. Check for alignment of moving parts, binding of moving parts, breakage of parts, mounting, and any other conditions that may affect its operation. A guard or other part that is damaged should be properly repaired or replaced by an authorized service center unless otherwise indicated elsewhere in this instruction manual.
Have defective switches replaced by authorized service center.
Do not use tool if switch does not turn it on and off.
- 20. AVOID USING A POWER TOOL FOR APPLICATIONS OTHER THAN THOSE SPECIFIED.** Never use a power tool for applications other than those specified in the instruction manual.
- 21. ENSURE SAFE OPERATION THROUGH CORRECT HANDLING.** Secure safe operation through correct handling by observing the instructions described herein.
Do not employ accessories other than those specified herein; otherwise, a hazardous condition may be created.
Never allow a power tool to be used by persons not familiar with correct handling (such as children) or by those who cannot handle the tool correctly.
- 22. CONFIRM THAT NO ITEMS SUCH AS AN ELECTRIC CABLE OR CONDUIT ARE BURIED INSIDE.** In places where live wiring may be hidden behind a wall, floor, ceiling, etc. do not hold or contact any metal parts of the tool. In such cases, metal parts could become electrically live and present a serious shock hazard.

23. **KEEP THE RIGHT PARTS IN THE RIGHT POSITIONS.** Do not remove covers and screws which have been factory-mounted. They perform important respective roles. Keep them in the right positions.
24. **SHOULD THE PLASTIC HOUSING OR HANDLE OF A POWER TOOL BE CRACKED OR DEFORMED, DO NOT USE IT.** Since cracked or deformed parts may lead to an operator receiving an electric shock, do not use such a power tool. Immediately have it repaired.
25. **SECURELY MOUNT ACCESSORIES AND BLADES TO THE TOOL MAIN BODY.** Extra care must be taken when using tools on elevated location (such as a roof ladder, scaffold, or the like) to prevent injury to someone on a lower level in the event the tool and/or accessory should drop.
26. **ALWAYS KEEP THE MOTOR AIR VENT FULLY OPENED.** A constantly open motor air vent is necessary to allow air to come in and out for cooling the motor. Do not allow it to become clogged up, even if dust is blown through it.
27. **OPERATE POWER TOOLS AT THE RATED VOLTAGE.** Operate power tools at voltages specified on their nameplates.
28. **NEVER TOUCH THE MOVING PARTS.** Never touch the moving parts such as blades, bits, cutters and others.
29. **STOP OPERATION IMMEDIATELY IF ANY ABNORMALITY IS DETECTED.** Should a power tool be detected as out of order or should other abnormalities be observed during operation, stop using the tool immediately.
30. **NEVER LEAVE TOOL RUNNING UNATTENDED. TURN POWER OFF.** Don't leave tool until it comes to a complete stop.
31. **CAREFULLY HANDLE POWER TOOLS.** Should a power tool be dropped or struck against hard materials inadvertently, it may be deformed, cracked, or damaged.
32. **DO NOT WIPE PLASTIC PARTS WITH SOLVENT.** Solvents such as gasoline, thinner, benzine, carbon tetrachloride, and alcohol may damage and crack plastic parts. Do not wipe them with such solvents. Wipe plastic parts with a soft cloth lightly dampened with soapy water.
33. **WHEN REPLACING A COMPONENT PART, ADOPT THE SAME TYPE.** When replacing a component part with a new one, adopt the same type of new part. Also, never attempt to repair a power tool yourself.
34. **SAVE THESE INSTRUCTIONS**

SERVICE AND REPAIRS

All quality tools will eventually require servicing or replacement of parts due to wear from normal use. These operations should **ONLY** be performed by an **AUTHORIZED HITACHI POWER TOOL REPAIR SHOP.**

REPLACEMENT PARTS

When servicing use only identical replacement parts.

DOUBLE INSULATION SYSTEM ENHANCES SAFE OPERATION

To enhance safe operation of this electric power tool, HITACHI has adopted a double insulation system. The term "double insulation" used here denotes an insulation system with two insulations physically separated and arranged between the electrically conductive material connected to the power supply and the outer frame subject to contact by the operator.

Thus, the power tool is termed double insulated and both the "回" mark and "Double insulation", or either one is indicated on the name plate.

While no external grounding is required with this system, normal safety precautions as outlined in this manual must still be followed.

To maintain the effectiveness of the double insulation system, follow the precautions described below:

1. Always contact your dealer or an authorized HITACHI power tool repair shop when assembling, disassembling or replacing parts other than accessories or carbon brushes. Improper assembly and/or replacement with wrong parts may result in eliminating the double insulation-feature.
2. Clean the exterior of the tool with a soft cloth moistened with soapy water, and dry thoroughly. Chloric solvent, gasoline, and thinner will cause plastic components to dissolve.

PRECAUTION ON USING ROTARY HAMMER

1. Always attach the side handle and securely grip the Rotary Hammer.
2. Do not touch the tool bit with bare hands after operation.
3. Do not wear gloves made of stuff liable to roll up such as cotton, wool, cloth or string, etc.
4. Wear ear protectors when using for extended periods.

NAME OF PARTS

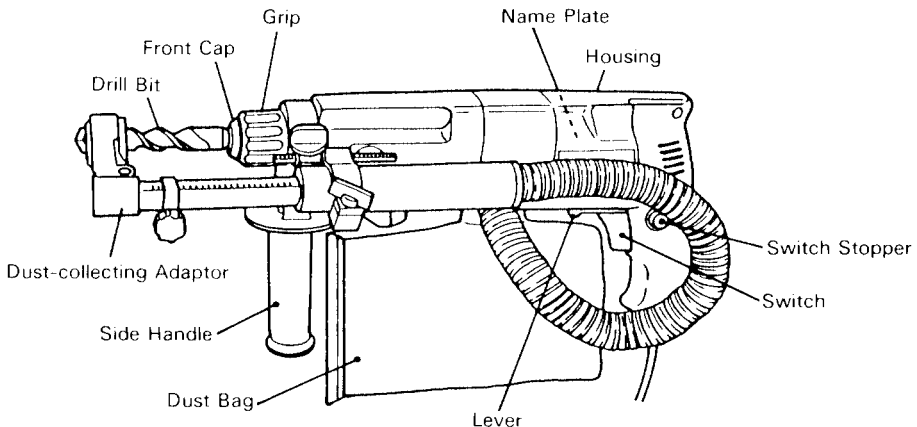

Fig. 1



DOUBLE INSULATION

SPECIFICATIONS

Motor	Single-Phase, Series Commutator Motor		
Power Source	Single-Phase, 115V AC 60Hz		
Current	4.6A		
Capacity	Concrete:	5 32" ~ 7 8"	
	Steel:	1 2"	
	Wood:	1-1 4"	
No-load Speed	0-1000 min.		
Full-load Impact Rate	4200 min.		
Weight	5.7 lbs		
Dust collecting adaptor			
Max. hole-drilling depth:	4" (adjustment possible between 0 and 4")		
Diameter of drill:	5 32"-7 8"		
Length of drill (total length):	10-5 8"		
Dust bag capacity:	0.11 gallon		

ACCESSORIES

CAUTION :

Recommended accessories for this Electric Power Tool are mentioned in this manual. The use of any other attachment or accessory might be hazardous.

STANDARD ACCESSORIES

- (1) Case (Modeled plastic) (Code No. 302211) 1
- (2) Side Handle (Code No. 302073) 1
- (3) Dust-collecting adaptor (Code No. 302074) 1
- (4) Dust Bag (Code No. 302048) 1
- |Number (3) and (4) refer to use on concrete|
- (5) Cap 1

OPTIONAL ACCESSORIES (sold separately)

1. Drilling anchor holes (Rotation - Striking)



+

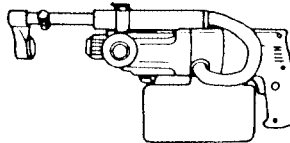

Drill Bit (round shank)

Drill external dia.	Total length	Code. No.	Drill external dia.	Total length	Code. No.	Drill external dia.	Total length	Code. No.
5 32"	4-9 16"	301873	11 32"	6-17 32"	301888	21 32"	6-11 16"	301903
3 16"	4-9 16"	301877	15 32"	6-11 16"	301893	3 4"	6-11 16"	301906
3 16"	6-17 32"	301878	15 32"	12-19 32"	301914	3 4"	12-19 32"	301920
7 32"	4-9 16"	301879	1 2"	6-11 16"	301895	25 32"	6-11 16"	301907
1 4"	6-17 32"	301883	9 16"	6-11 16"	301897	7 8"	6-11 16"	301909
9 32"	6-17 32"	301884	19 32"	6-11 16"	301900			
5 16"	6-17 32"	301886	5 8"	6-11 16"	301901			
21 64"	8-1 2"	301911	5 8"	12-19 32"	301919			

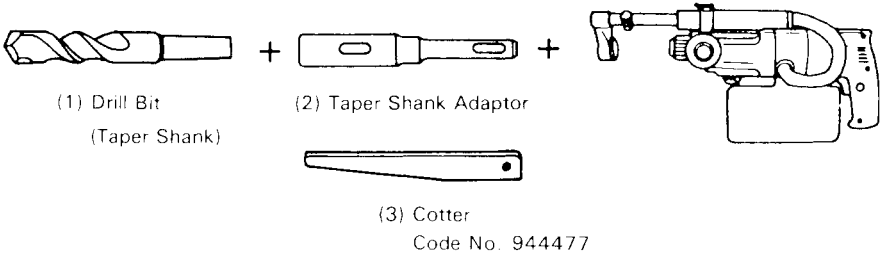

External dia.	Code No.
7 16"	944460
31 64"	944461
9 16"	944462
73 128"	944500
11 16"	944463
27 32"	944464

Taper mode	Code No.	Applicable drill bit
Morse taper (No. 1)	301922	Drill bit (Taper shank)
		7 16"
		31 64"
		9 16"
Morse taper (No. 2)	301923	Drill bit (Taper shank)
		27 32"
A taper	301924	Taper shank adaptor formed A-taper or B-taper is provided as an optional accessory, but drill bit for it is not provided.
B taper	301925	

2. Knock in anchor (Rotation · Striking)

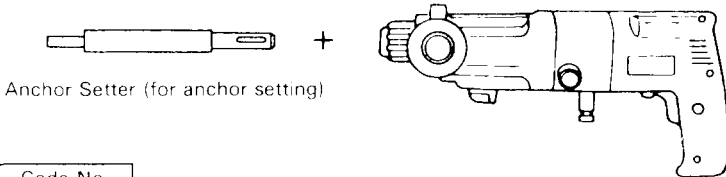

Anchor size	Code No.
W1 4"	301933
W5 16"	301932
W3 8"	301931

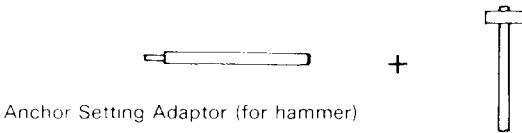

Anchor size	Code No.
W1 4"	971799
W5 16"	971800
W3 8"	971801
W1 2"	971802
W5 8"	971803

3. Drilling holes (Rotation only)
for drilling in steel or wood

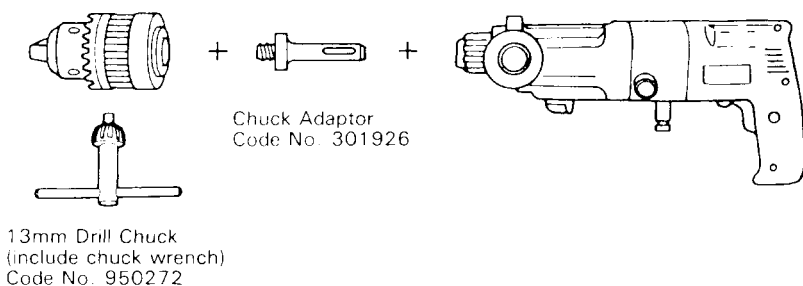

4. Driving Screws (Rotation only)

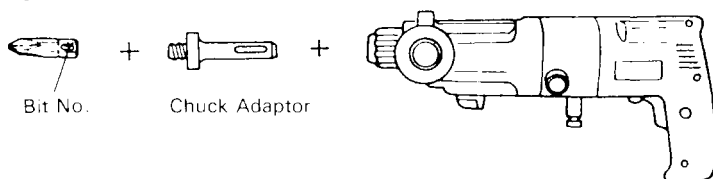

Bit No.	Screw Size	Length	Code No.
No. 2	1 8" ~ 13 64"	1"	971511Z
No. 3	15 64" ~ 5 16"	1"	971512Z

APPLICATIONS

Rotation and striking function

- Drilling anchor holes
- Drilling holes in concrete
- Drilling holes in tile

Rotation only function

- Drilling in steel or wood
(with optional accessories)
- Tightening machine screws, wood screws.

PRIOR TO OPERATION

1. Power source:

Ensure that the power source to be utilized conforms to the power requirements specified on the product nameplate.

2. Power switch:

Ensure that the power switch is in the OFF position. If the plug is connected to a power receptacle while the power switch is in the ON position, the power tool will start operating immediately, inviting serious accident.

3. Extension cord:

When the work area is removed from the power source, use an extension cord of sufficient thickness and rated capacity. The extension cord should be kept as short as practicable.

CAUTION:

- Damaged cord must be replaced or repaired.

4. Confirming condition of the environment:

Confirm that the work site is placed under appropriate conditions conforming to prescribed precautions.

5. Mounting the drill bit (Fig. 2)

- (1) The grip can manually be rotated with an angle of 60°. Fully turn the grip clockwise so that the ■ mark in the grip is aligned with the ■ mark in the front cap.
- (2) Align the round groove of the drill bit with the mark on the front cap and insert it until it touches the rear of the hole.
- (3) Turn the grip in the direction of "Lock →" so that the ■ mark in the grip is aligned with the ● mark in the front cap. The drill bit is locked. Remove the drill bit in the reverse order to installation. Always use HITACHI genuine drill bit.

6. Selecting the drive bit

Screw heads or bits will be damaged unless a bit appropriate for the screw diameter is employed to drive in the screws.

7. Confirm the direction of bit rotation (Fig. 3)

The bit rotates clockwise (viewed from the rear side) by pushing the R-side of the reversing switch lever. The L side of the lever is pushed to turn the bit counterclockwise.

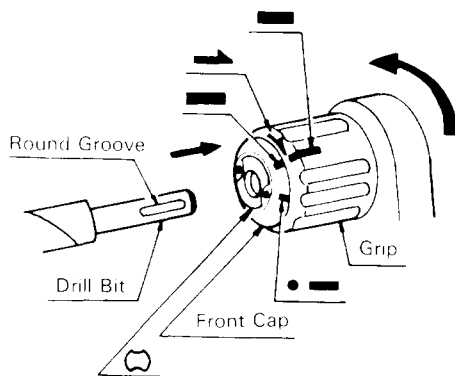

Fig. 2

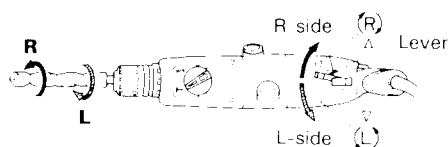

Fig. 3

HOW TO USE

1. Switch operation

The rotational speed of the drill bit can be controlled by varying the amount that the trigger switch is pulled. Speed is low when the trigger switch is pulled slightly and increases as the switch is pulled more. Continuous operation may be attained by pulling the trigger switch and depressing the stopper. To turn the switch OFF, pull the trigger switch again to disengage the stopper, and release the trigger switch to its original position.

2. Rotation · Striking

This rotary hammer can be set to rotation and striking mode by rotating the selector lever fully counterclockwise to **T** mark. (Fig. 4)

- (1) Mount the drill bit.
- (2) Pull the trigger switch after applying the drill bit tip to the drilling position. (Fig. 5)
- (3) Pushing the rotary hammer forcibly is not necessary at all. Pushing slightly so that drill dust comes out gradually is just sufficient.

CAUTION

When the drill bit touches construction iron bar, the bit will stop immediately and the rotary hammer will react to revolve. Therefore please grip the side handle and handle tightly as shown in Fig. 5.

3. Using the dust-collecting adaptor and dust bag.

Using this unit with the dust-collecting adaptor and dust bag attached creates a more hygienic working environment free of flying dust. Attach as shown in Fig. 1. The unit can be used as an ordinary rotary hammer when the dust-collecting adaptor and dust bag is not attached.

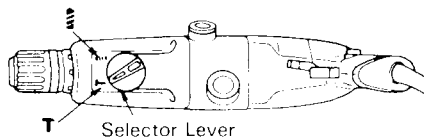

Fig. 4

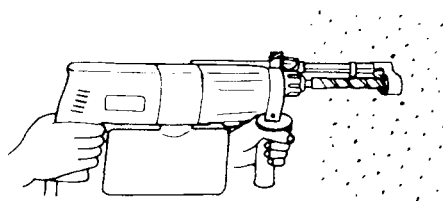

Fig. 5

(1) Attaching the dust-collecting adaptor and the dust bag.

a) Attaching the dust-collecting adaptor.

Loosen the knob bolt on the side handle and insert the attachment rod on the dust-collecting adaptor in the attachment hole. The adaptor can be inserted from either direction A or B (see **Fig. 6**). Insert and push in the hose in the hose attachment hole of the main unit until it reaches the inner surface (depth 5 8") and confirm that it is firmly fixed. (see **Fig. 7**)

b) Attaching the dust bag.

Insert the dust bag firmly in the dust bag attachment hole on the main unit and fasten securely (see **Fig. 8**).

CAUTIONS

The dust-collecting adaptor and dust bag is made for use when drilling concrete. Do not use for drilling holes in metal or wood.

(2) Adjusting the dust-collecting adaptor.

a) Adjusting the position of the dust-collecting adaptor.

After firmly insert the drill bit, loosen the wing bolt and drill bit tip and the end of the dust-collecting adaptor in contact with each other (see **Fig. 9**).

b) Setting the hole-drilling depth.

Move the stopper to determine the stroke. The stroke is the hole drilling depth. (see **Fig. 9**).

The maximum hole-drilling depth when using the dust-collecting adaptor is 4".

It is possible when using the dust-collecting adaptor to use HITACHI drill bits up to a total length of 8-1 2". A hole-drilling depth of 1 3 4" will allow dust-collecting when the total length of the drill bit is 4-9 16".

(3) Drilling holes

When drilling holes, secure the main unit so that the end of the dust-collecting adaptor contacts with the concrete surface perfectly during drilling. Dust-collecting effectiveness is reduced if the adaptor is not in contact with the surface (see **Fig. 10**).

(4) Removing dust

Excessive dust in the dust bag will reduce dust-collecting effectiveness. Remove dust from the dust bag regularly.

Remove the dust bag from the main unit, pull out the rail and throw away the dust and clean. (see **Fig. 11**)

4. When not using the dust-collecting adaptor

When removing the dust-collecting adaptor and the dust bag to use as a normal rotary hammer, insert the provided cap in the hose attachment hole. (see **Fig. 12**) After removing the dust bag, the air blowing out from the attachment hole is reduced and no air will blow onto your face.

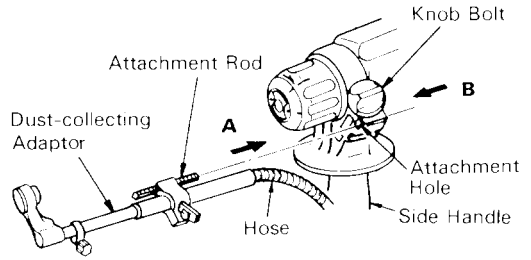

Fig. 6

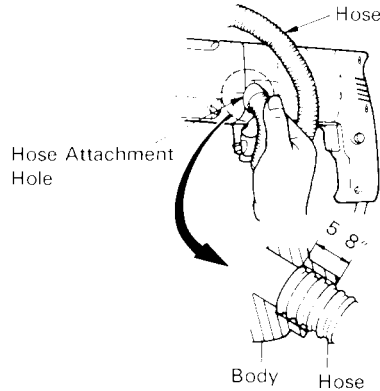

Fig. 7

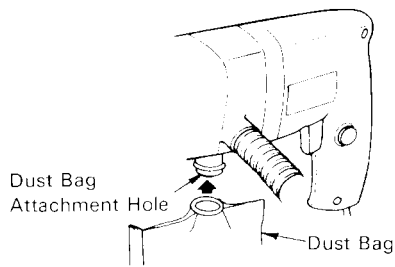

Fig. 8

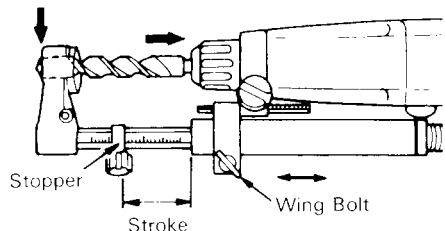







Fig. 9

5. Rotation only

Remove the dust-collecting adaptor as it cannot be used. Insert the provided cap in the hose attachment hole.

The rotary hammer can be set to rotation only mode by rotating the selector lever fully clockwise to  mark. (Fig. 13)

To drill a wood or metal material using the supplied drill chuck and chuck adaptor, proceed as follows. Installing drill chuck and chuck adaptor (Fig. 14):

- (1) Fully turn the grip clockwise so that  mark in the grip is aligned with  mark in the front cap.
- (2) Align the slot of the chuck adaptor with the  mark on the front cap and insert it until it touches the rear of the hole.
- (3) Turn the grip so that  mark in the grip is aligned with  mark in the front cap.

The chuck adaptor is locked.

CAUTIONS

Application of force more than necessary will not only expedite work at all, but will deteriorate the tip edge of the drill bit and reduce the service life of the rotary hammer in addition. Drill bit may snap off while withdrawing the rotary hammer from the drilled hole. For withdrawing, it is important to use a pushing motion.

Do not attempt to drill anchor holes or holes in concrete with the machine set in the rotation only function.

Do not attempt to use the rotary hammer in the rotation and striking function with the drill chuck and chuck adaptor attached. This would seriously shorten the service life of every component of the machine.

6. When driving machine screws (Fig. 15)

First, insert the bit into the socket in the end of the chuck adaptor.

Next, mount the chuck adaptor on the main unit using procedures described in 5 (1), (2), (3), put the tip of the bit in the slots in the head of the screw, grasp the main unit and tighten the screw.

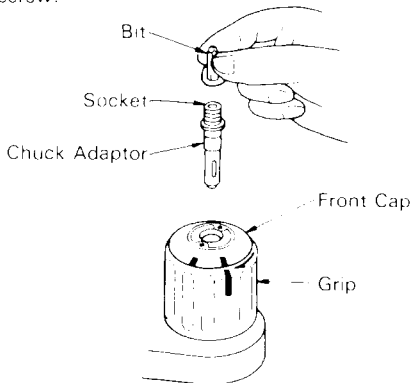

Fig. 15

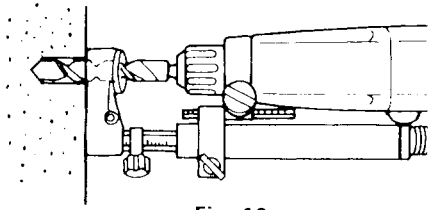

Fig. 10

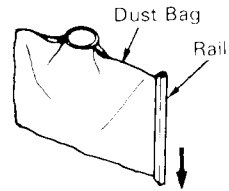

Fig. 11

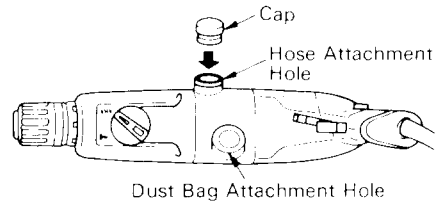

Fig. 12

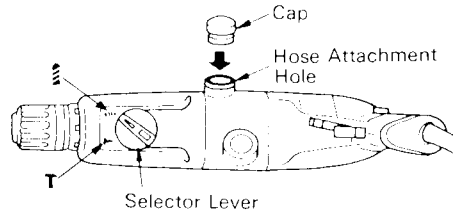

Fig. 13

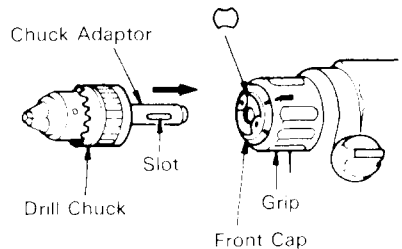

Fig. 14

CAUTIONS

Exercise care not to excessively prolong driving time, otherwise, the screws may be damaged by excessively force.

Apply the rotary hammer perpendicularly to the screw head when driving a screw; otherwise, the screw head or bit will be damaged, or driving force will not be fully transferred to the screw.

Do not attempt to use the rotary hammer in the rotation and striking function with the chuck adaptor and bit attached.

7. When driving wood screws (Fig. 15)

- (1) Selecting a suitable driver bit
Employ plus-head screws, if possible, since the driver bit easily slips off the heads of minus-head screws.
- (2) Driving in wood screws
Prior to driving in wood screws, make pilot holes suitable for them in the wooden board. Apply the bit to the screw head grooves and gently drive the screws into the holes. After rotating the rotary hammer at low speed for a while until a wood screw is partly driven into the wood, squeeze the trigger more strongly to obtain the optimum driving force.

CAUTION

Exercise care in preparing a pilot hole suitable for the wood screw taking the hardness of the wood into consideration. Should the hole be excessively small or shallow, requiring much power to drive the screw into it, the thread of the wood screw may sometimes be damaged.

8. How to use the drill bit (taper shank) and the taper shank adaptor.

- (1) Mount the taper shank adaptor to the rotary hammer. (Fig. 16)
- (2) Mount the drill bit (taper shank) to the taper shank adaptor. (Fig. 16)
- (3) Turn the switch ON, and drill a hole in prescribed depth.
- (4) To remove the drill bit (taper shank), insert the cotter into the slot of the taper shank adaptor and strike the head of the cotter with a hammer supporting on the rest. (Fig. 17)

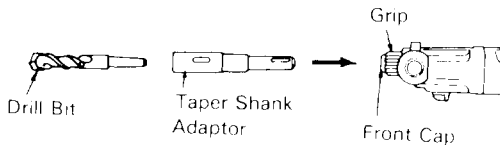

Fig. 16

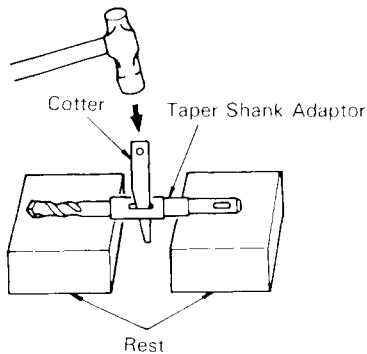

Fig. 17

LUBRICATION

Low viscosity grease is applied to this rotary hammer so that it can be used for a long period without replacing the grease. Please contact the nearest service agent for grease replacement when any grease is leaking from loosened screw.

Further use of the rotary hammer despite the grease shortage causes seizure to reduce the service life.

CAUTION

A specific grease is used with this machine, therefore, the normal performance of the machine may be badly affected by use of other grease. Please be sure to let one of our service agents undertake replacement of the grease.

MAINTENANCE AND INSPECTION

1. Inspecting the drill bits

Since use of a dull tool will cause motor malfunctioning and degraded efficiency, replace the drill bits with a new one or resharpening without delay when abrasion is noted.

2. Inspecting the mounting screws

Regularly inspect all mounting screws and ensure that they are properly tightened.

Should any of the screws be loose, retighten them immediately. Failure to do so could result in serious hazard.

3. Inspecting the carbon brushes

For your continued safety and electrical protection, carbon brush inspection and replacement on this tool should ONLY be performed by an AUTHORIZED HITACHI POWER TOOL REPAIR SHOP.

4. Maintenance of the motor

The motor unit winding is the very "heart" of the power tool. Exercise due care to ensure the winding does not become damaged and or wet oil or water.

NOTE

Due to HITACHI's continuing program of research and development, the specifications herein are subject to change without prior notice.

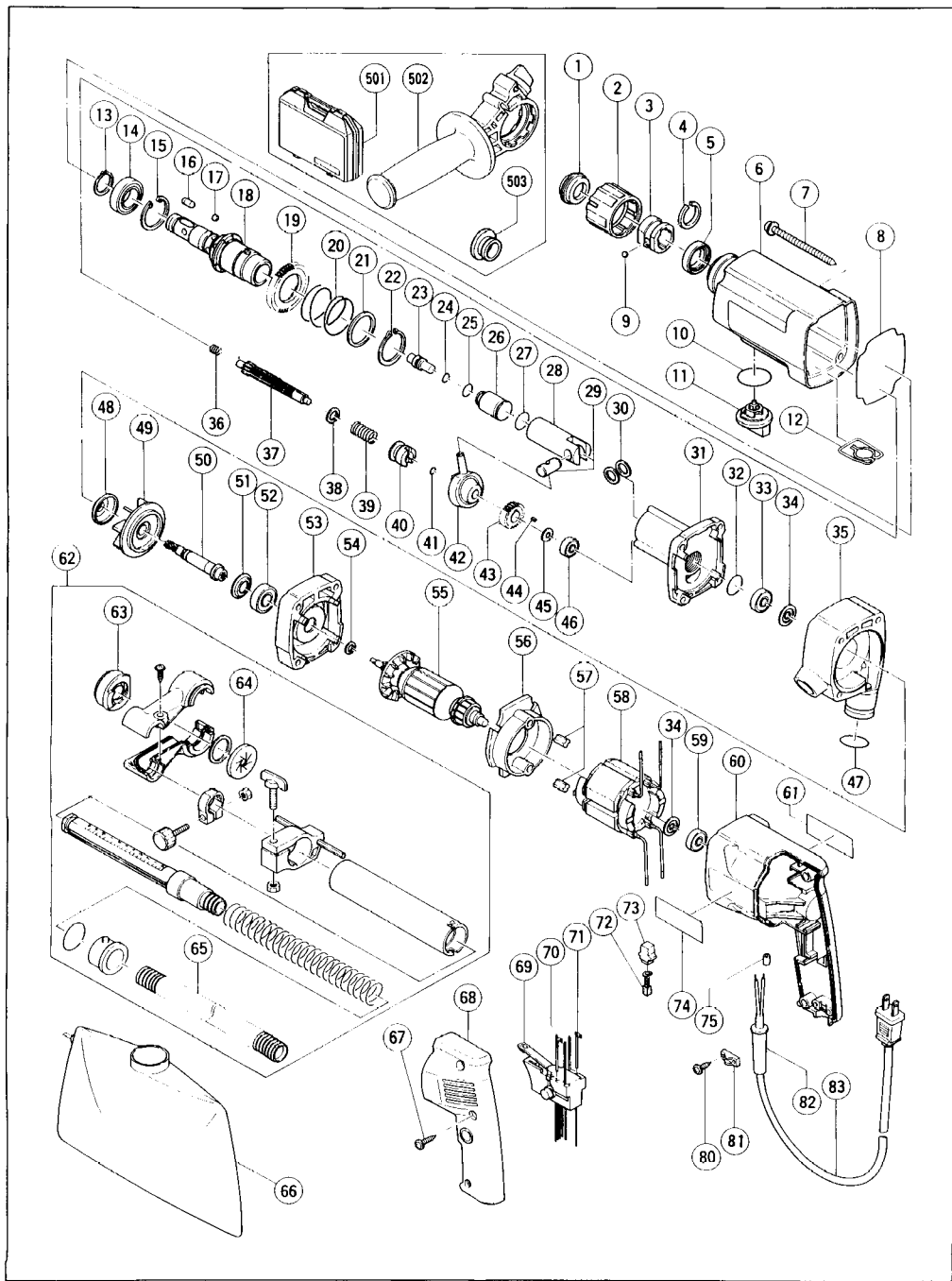

Item No.	Part Name
1	Front Cap
2	Grip
3	Needle Holder
4	C-Type Spring
5	Oil Seal
6	Gear Cover
7	Tapping Screw (W/Flange) D5×90
8	Rubber Seal
9	Steel Ball D6.35
10	O-Ring (S-30)
11	Change Lever
12	Spring (C)
13	Retaining Ring For D20 Shaft
14	Ball Bearing (6904CM)
15	Retaining Ring For D37 Hole
16	Needle Roller
17	Steel Ball D5.556
18	Cylinder
19	Second Gear
20	Spring (A)
21	Washer (A)
22	Retaining Ring For D30 Shaft
23	Second Hammer
24	O-Ring (B)
25	O-Ring (FPM 810)
26	Striker
27	O-Ring (A)
28	Piston
29	Piston Pin
30	Washer (C)
31	Inner Cover
32	O-Ring (P-22)
33	Ball Bearing (608DDMC2EPS2S)
34	Washer (A)
35	Casing (B)
36	Spring (B)
37	Second Shaft
38	Washer (B)
39	Clutch Spring
40	Clutch
41	O-Ring (S-8)
42	Reciprocator

Item No.	Part Name
43	First Gear
44	Feather Key 3×3×8
45	Spacer
46	Ball Bearing (626VVMC2ERPS2S)
47	O-Ring
48	Seal Plate
49	Dust Fan
50	Dust Shaft
51	Dust Washer
52	Ball Bearing (6001DDUCMPS2S)
53	Casing (A)
54	Rubber Sleeve
55	Armature
56	Fan Guid Ass'y
57	Rubber Bushing
58	Stator
59	Ball Bearing (608VVMC2EPS2L)
60	Housing
61	Name Plate
62	Dust Collection Adapter Ass'y
63	Nozzle Seal
64	Rubber Cap
65	Hose
66	Dust Bag
67	Tapping Screw (W/Flange) D4×20
68	Handle Cover
69	Speed Control Switch
70	Internal Wire (B)
71	Internal Wire (B)
72	Carbon Brush
73	Brush Holder
74	HITACHI Label
75	Tube (D)
80	Tapping Screw (W/Flange) D4×16
81	Cord Clip
82	Cord Armor
83	Cord
501	Case
502	Side Handle
503	Cap

Parts are subject to possible modification without notice due to improvements.

Hitachi Koki Co.,Ltd.

Nippon Bldg., 2-6-2, Ohtemachi,
Chiyoda-Ku, Tokyo 100, Japan

907

Code No. C99037661 N

Printed in Japan