

## ELECTRIC TOOL PARTS LIST

■ DRY CUT METAL SAW  
Model CD 14F

2001・3・30  
(E1)

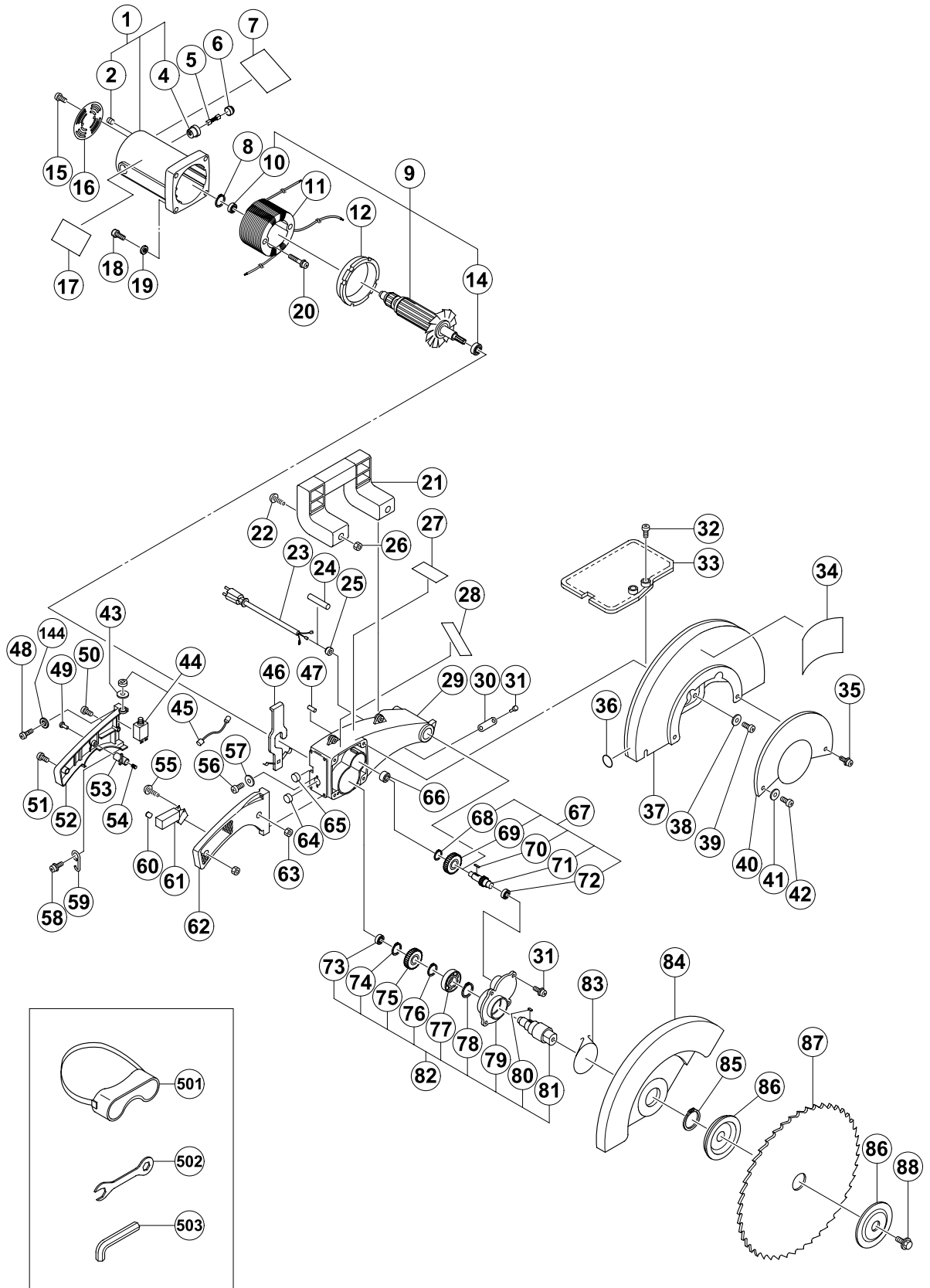

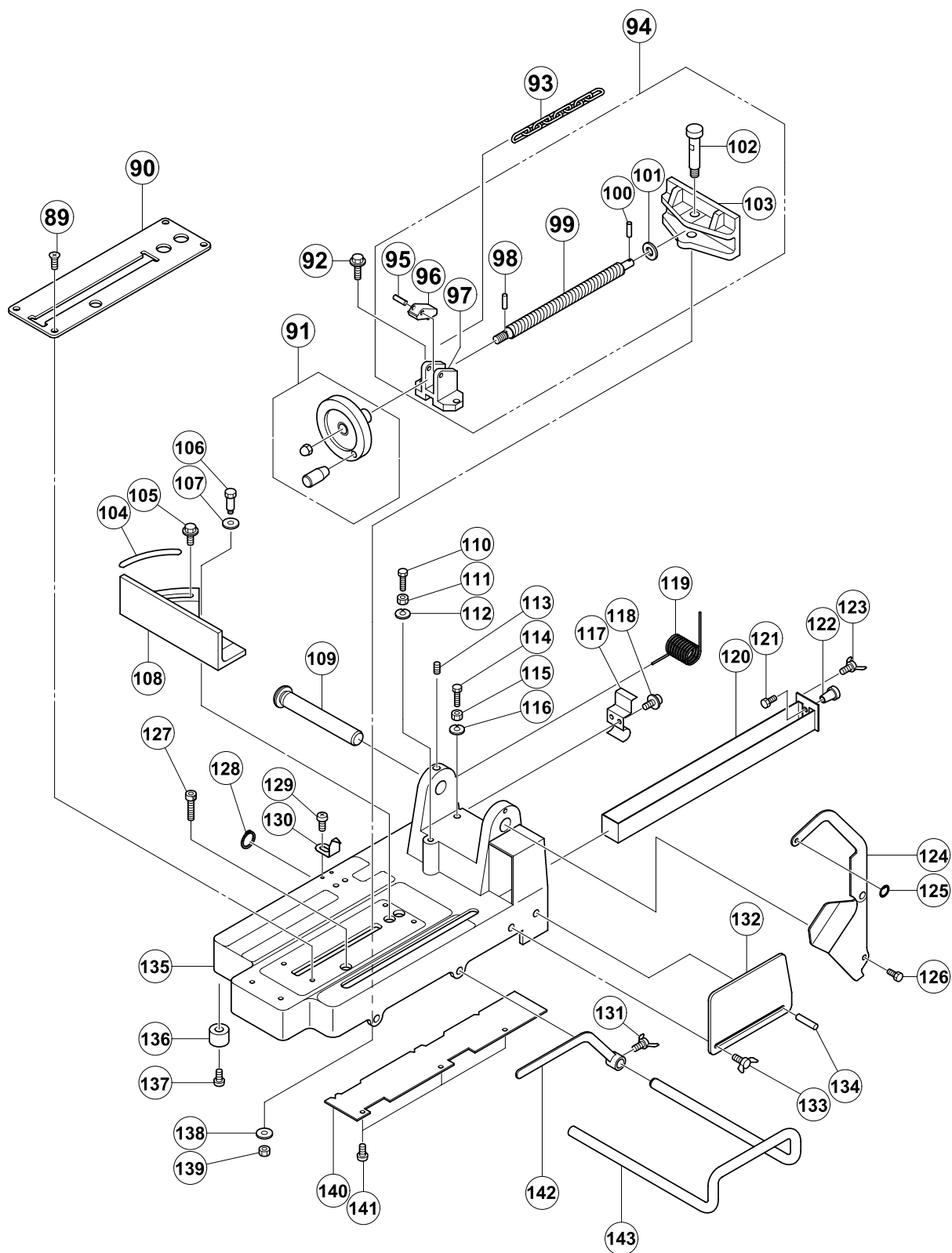

**PARTS**

CD 14F

ITEM NO.	CODE NO.	DESCRIPTION	NO. USED	REMARKS
1	320-058	HOUSING ASS'Y	1	INCLUD.2,4
2	320-041	HEX. SOCKET SET SCREW	2	
4	320-059	BRUSH HOLDER	2	
5	320-078	CARBON BRUSH (1 PAIR)	2	
6	320-060	BRUSH CAP	2	
7		NAME PLATE	1	
8	320-061	WAVE WASHER	1	
9	320-077	ARMATURE ASS'Y	1	INCLUD.10,14
10	620-0VV	BALL BEARING 6200VVCMP2L	1	
11	320-062	STATOR	1	
12	320-063	FAN GUIDE	1	
14	320-064	BALL BEARING 6002LLU	1	
15	949-217	MACHINE SCREW M4X12 (10 PCS.)	2	
16	320-057	TAIL COVER	1	
17	320-082	WARNING LABEL (B)	1	
18	949-258	MACHINE SCREW M6X20 (10 PCS.)	4	
19	949-455	SPRING WASHER M6 (10 PCS.)	4	
20	977-749	MACHINE SCREW (W/SP. WASHER) M5X80	2	
21	319-989	HANDLE	1	
22	949-664	HEX. SOCKET HD. BOLT M5X30 (10 PCS.)	2	
23	320-051	CORD	1	
24	319-997	CORD SLEEVE	1	
25	319-998	PROTECTION RUBBER	1	
26	302-012	NUT M5 (BLACK)	2	
27	320-081	WARNING LABEL (A)	1	
28		OVERLOAD LABEL	1	
29	320-068	GEAR CASE	1	
30	319-999	CORD CLAMP	1	
31	987-512	MACHINE SCREW (W/SP. WASHER) M5X16	6	
32	949-216	MACHINE SCREW M4X10 (10 PCS.)	2	
33	319-990	EYE SHIELD	1	
34		HITACHI LABEL	1	
35	949-236	MACHINE SCREW M5X10 (10 PCS.)	1	
36		LABEL	1	
37	319-991	SAW COVER	1	
38	319-992	BOLT WASHER M6	4	
39	319-993	MACHINE SCREW M6X15	4	
40	319-994	SUB COVER	1	
41	319-995	FLAT WASHER M5	1	
42	319-996	MACHINE SCREW M5X12	1	
43	320-006	BOLT WASHER M12	1	
44	320-052	OVERLOAD SWITCH 20A	1	
45	320-065	LEAD WIRE	1	
46	320-066	SPINDLE LOCK	1	
47	320-067	BEARING LOCK	1	
48	949-240	MACHINE SCREW M5X18 (10 PCS.)	3	
49	320-005	LOCK-OFF BUTTON	1	
50	320-004	MACHINE SCREW M5X30 (10 PCS.)	1	
51	949-243	MACHINE SCREW M5X25 (10 PCS.)	1	
52	320-013	HANDLE COVER	1	
53	320-007	LOCK SWITCH	1	

**PARTS**

CD 14F

ITEM NO.	CODE NO.	DESCRIPTION	NO. USED	REMARKS
54	320-008	SWITCH SPRING	1	
55	311-945	TAPPING SCREW (W/FLANGE) D4X10 (BLACK)	2	
56	320-010	MACHINE SCREW M5X8 (10 PCS.)	1	
57	973-879	TOOTHED LOCK WASHER M5	1	
58	320-002	MACHINE SCREW M5X23	1	
59	320-003	HOOK	1	
60	320-009	WIRE CONNECTOR	1	
61	320-053	SWITCH	1	
62	320-014	SWITCH HANDLE	1	
63	302-012	NUT M5 (BLACK)	2	
64	320-012	PROTECTION RUBBER	1	
65	320-011	PROTECTION RUBBER	1	
66	320-069	NEEDLE BEARING (HK1212)	1	
67	320-070	DRIVE SHAFT ASS'Y	1	INCLUD.68-72
68	939-546	RETAINING RING FOR D18 SHAFT (10 PCS.)	1	
69	320-072	HELIX GEAR	1	
70	930-511	FEATHER KEY 4X4X10	1	
71	320-071	DRIVE SHAFT	1	
72	600-0VV	BALL BEARING 6000VVCMP2L	1	
73	608-VVM	BALL BEARING 608VVC2PS2L	1	
74	939-548	RETAINING RING FOR D22 SHAFT (10 PCS.)	1	
75	320-076	SPUR GEAR	1	
76	965-469	RETAINING RING FOR D25 SHAFT	1	
77	600-5VV	BALL BEARING 6005VVPS2L	1	
78	948-227	RETAINING RING FOR D47 HOLE	1	
79	320-075	GEAR COVER	1	
80	948-015	FEATHER KEY 5X5X10	1	
81	320-074	MAIN SPINDLE	1	
82	320-073	MAIN SPINDLE ASS'Y	1	INCLUD.73-81
83	320-000	SPRING (B)	1	
84	320-015	SAFETY COVER	1	
85	002-525	RETAINING RING FOR D45 SHAFT	1	
86	320-054	WHEEL WASHER	2	
87	320-056	TCT SAW BLADE 355MMXD25.4 HOLE-NT80	1	
88	320-001	HEX. WASHER HD. BOLT	1	
89	320-033	FLAT HD SCREW M5X15	4	
90	320-032	SLIDE BASE	1	
91	320-079	SCREW HANDLE	1	
92	307-367	HEX. SOCKET HD. BOLT (W/WASHERS) M8X30	2	
93	320-024	CHAIN	1	
94	320-016	QUICK LOCK VISE ASS'Y	1	INCLUD.95-103
95	949-576	ROLL PIN D6X32 (10 PCS.)	1	
96	320-018	CLUTCH	1	
97	320-017	SCREW HOLDER	1	
98	320-019	ROLL PIN 1/8"X1/8"	1	
99	320-020	VISE SCREW	1	
100	949-900	ROLL PIN D3X14 (10 PCS.)	1	
101	320-021	BOLT WASHER	1	
102	320-023	VISE SHAFT	1	
103	320-022	VISE (A)	1	
104	320-027	SCALE	1	



