

ELECTRIC TOOL PARTS LIST

■ SLIDE COMPOUND SAW
Model C 12FSA

2001·9·14

(E2)

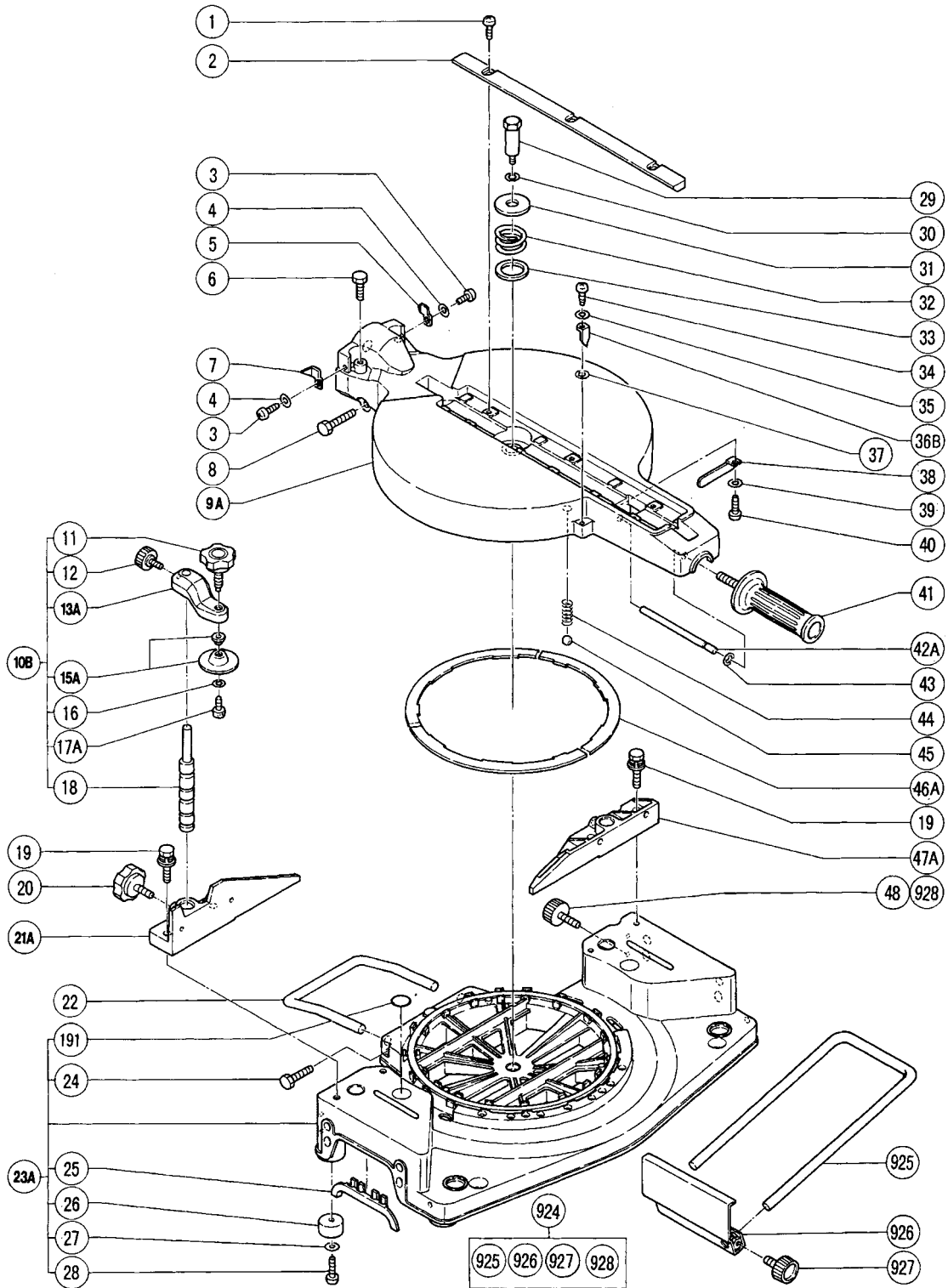

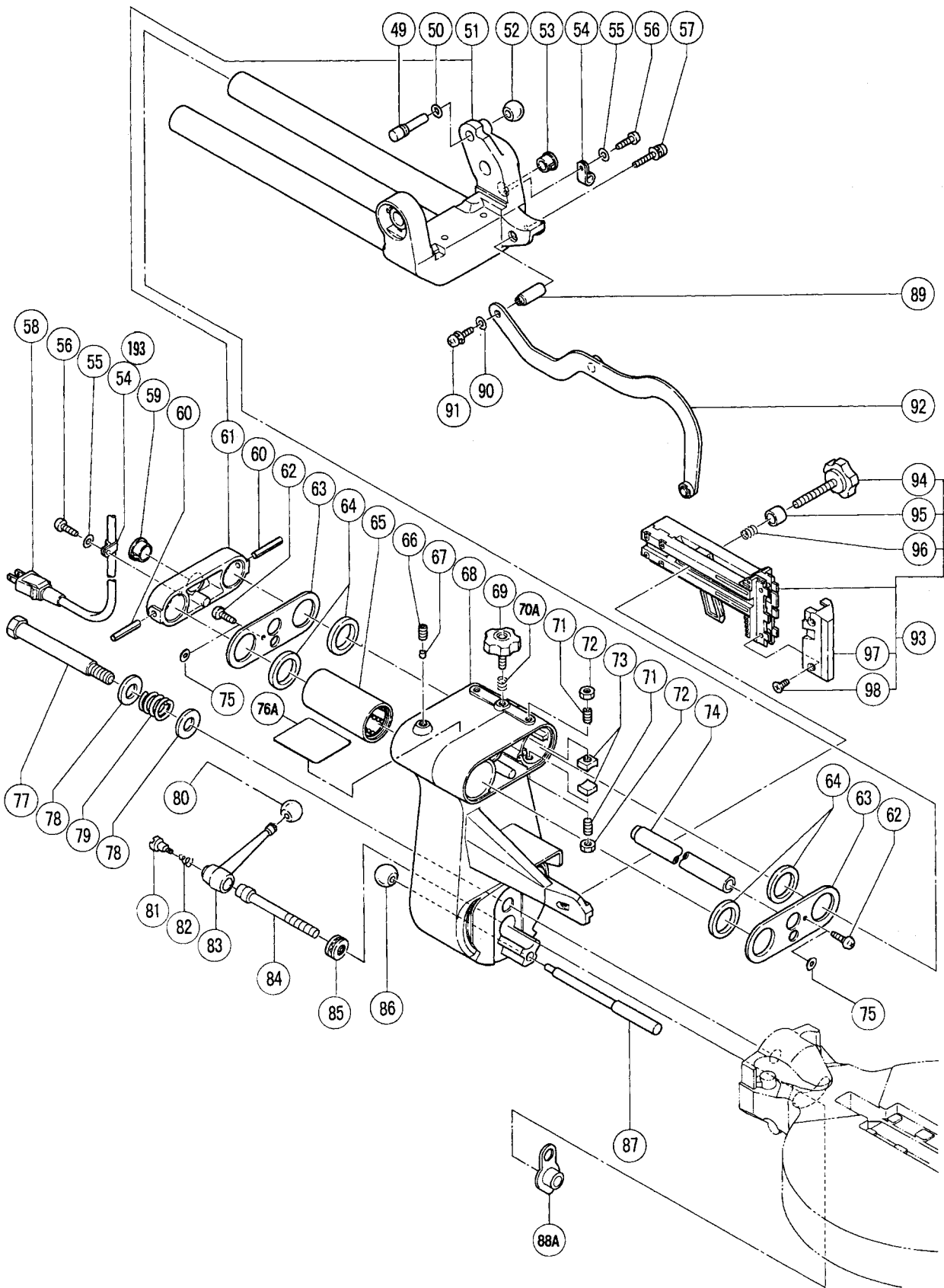

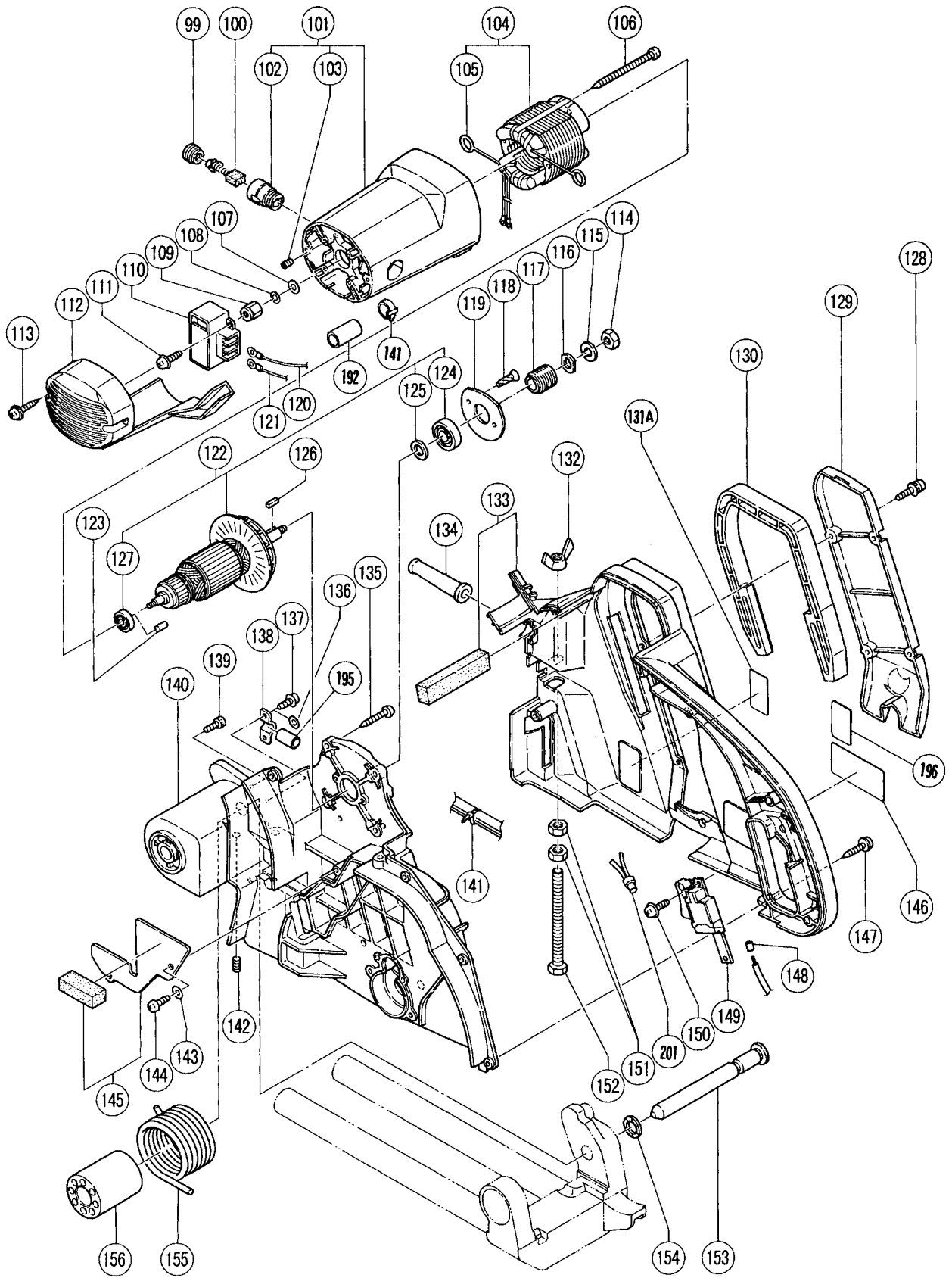

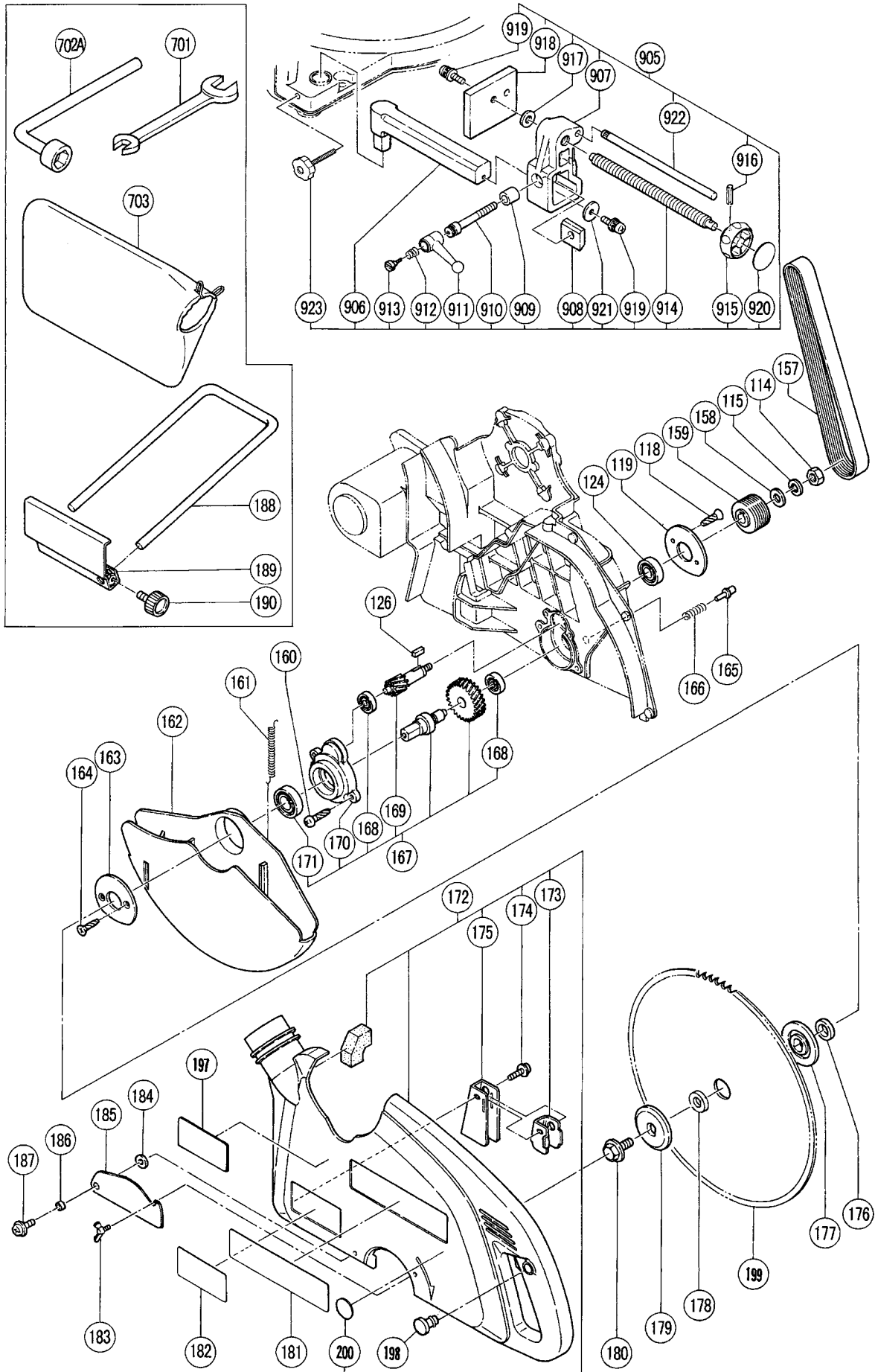

PARTS

C 12FSA

ITEM NO.	CODE NO.	DESCRIPTION	NO. USED	REMARKS
1	949-258	MACHINE SCREW M6X20 (10 PCS.)	6	
2	998-818	TABLE INSERT	2	
3	949-215	MACHINE SCREW M4X8 (10 PCS.)	2	
4	949-429	BOLT WASHER M4 (10 PCS.)	2	
5	310-718	INDICATOR (B)	1	
6	303-409	NYLOCK BOLT M8X25	2	
7	310-719	INDICATOR (C)	1	
8	303-410	NYLOCK BOLT M8X40	1	
9A	310-733	TURN TABLE	1	
10B	310-747	WISE ASS'Y	1	INCLUD.11-13A,15A-18
11	308-396	KNOB BOLT M10	1	
12	998-836	KNOB BOLT M6X11	1	
13A		SCREW HOLDER	1	
15A	319-974	WISE PLATE SET	1	
16	996-722	WASHER	1	
17A	996-247	MACHINE SCREW (W/WASHERS) M5X12 (BLACK)	1	
18	310-748	WISE SHAFT	1	
19	307-221	BOLT (W/WASHERS) M8X35 (BLACK)	4	
20	303-450	KNOB BOLT M8X20	1	
21A	310-732	FENCE (B)	1	
22	310-886	HOLDER (B)	1	
* 23A	305-133	BASE ASS'Y	1	INCLUD.24-28
* 23A	320-289	BASE ASS'Y	1	INCLUD.24,26-28,191 FOR USA
24	949-616	BOLT M6X25 (10 PCS.)	1	
* 25	303-434	BASE GRIP	2	EXCEPT FOR USA
26	964-851	BASE RUBBER	5	
27	949-431	BOLT WASHER M5 (10 PCS.)	5	
28	949-241	MACHINE SCREW M5X20 (10 PCS.)	5	
29	303-736	SHAFT (A)	1	
30	949-457	SPRING WASHER M8 (10 PCS.)	1	
31	967-143	WASHER (R)	1	
32	306-086	SPRING (E)	1	
33	967-779	WASHER (G)	1	
34	949-215	MACHINE SCREW M4X8 (10 PCS.)	1	
35	949-429	BOLT WASHER M4 (10 PCS.)	1	
36B	318-822	INDICATOR	1	
37	949-429	BOLT WASHER M4 (10 PCS.)	1	
38	998-814	SPACER	1	
39	949-429	BOLT WASHER M4 (10 PCS.)	1	
40	949-217	MACHINE SCREW M4X12 (10 PCS.)	1	
41	307-746	SIDE HANDLE	1	
42A	998-815	SHAFT	1	
43	974-577	RETAINING RING (E-TYPE) FOR D7 SHAFT	1	
44	305-684	SPRING (D)	1	
45	959-153	STEEL BALL D12.7 (10 PCS.)	1	
46A	303-399	LINER	3	
47A	310-731	FENCE (A)	1	
* 48	302-503	KNOB BOLT M6X22	2	EXCEPT FOR USA
49	303-411	SET PIN (A)	1	
50	872-645	O-RING (P-9)	1	
* 51	312-694	HINGE ASS'Y	1	INCLUD.61

PARTS

C 12FSA

ITEM NO.	CODE NO.	DESCRIPTION	NO. USED	REMARKS
* 51	320-290	HINGE ASS'Y	1	INCLUD.61 FOR USA
	967-896	GRIP	1	
* 53	305-152	ONE-TOUCH BUSHING	1	EXCEPT FOR USA
* 54	948-193	NYLON CLIP	2	EXCEPT FOR USA
* 55	949-429	BOLT WASHER M4 (10 PCS.)	2	
* 55	949-429	BOLT WASHER M4 (10 PCS.)	1	FOR USA
* 56	949-217	MACHINE SCREW M4X12 (10 PCS.)	2	
* 56	949-217	MACHINE SCREW M4X12 (10 PCS.)	1	FOR USA
	986-274	MACHINE SCREW (W/WASHERS) M5X25	1	
* 58	500-439Z	CORD	1	(CORD ARMOR D10.1)
* 58	500-407Z	CORD	1	(CORD ARMOR D8.8) FOR USA
* 59	975-012	ONE-TOUCH BUSHING	1	EXCEPT FOR USA
	949-686	ROLL PIN D6X40 (10 PCS.)	2	
* 61	305-170	SUPPORT	1	
* 61	307-222	SUPPORT	1	FOR USA
	949-217	MACHINE SCREW M4X12 (10 PCS.)	2	
* 63	305-140	PACKING COVER	2	
* 63	310-863	PACKING COVER (C)	2	FOR USA
	996-226	FELT	4	
	998-825	BALL BUSHING	1	
	966-458	HEX. SOCKET SET SCREW M8X8	1	
	976-301	BEARING LOCK	1	
	310-734	HOLDER (A)	1	
	996-225	KNOB BOLT M8X20	1	
	70A 947-859	LOCK SPRING	1	
	974-500	HEX. SOCKET SET SCREW M8X16	4	
	949-568	LOCK NUT M8 (10 PCS.)	4	
	996-223	BUSHING	4	
* 74	310-737	PIPE	1	EXCEPT FOR USA
	949-429	BOLT WASHER M4 (10 PCS.)	2	
		CAUTION LABEL (A)	1	
	310-712	HINGE SHAFT	1	
	949-438	BOLT WASHER M16 (10 PCS.)	2	
	310-887	SPRING (B)	1	
	968-636	GRIP (B)	1	
	305-180	CLUTCH SCREW	1	
	305-179	CLUTCH SPRING	1	
	310-890	CLAMP LEVER	1	
	310-888	BOLT (LEFT HAND) M12X165	1	
	939-381	THRUST BEARING (51101)	1	
	967-896	GRIP	1	
	310-711	SET PIN	1	
	310-889	SCREW HOLDER	1	
	309-990	SHAFT (B)	1	
	998-987	WASHER	1	
	990-541	MACHINE SCREW (W/WASHERS) M5X16	1	
	310-723	LINK	1	
	315-277	GUARD ASS'Y (A)	1	INCLUD.94-98
	303-408	KNOB BOLT M8X60	1	
	303-404	SLEEVE	1	
	873-923	GOVERNOR SPRING	1	

PARTS

C 12FSA

ITEM NO.	CODE NO.	DESCRIPTION	NO. USED	REMARKS
97	303-403	GUARD (C)	1	
98	998-850	FLAT HD. SCREW (BRASS) M4X6	4	
99	996-259	BRUSH CAP	2	
100	999-038	CARBON BRUSH (1 PAIR)	2	
101	315-547	HOUSING ASS'Y	1	INCLUD.102,103
102	976-807	BRUSH HOLDER	2	
103	966-426	HEX. SOCKET SET SCREW M5X6	2	
* 104	340-336	STATOR ASS'Y 100V-120V	1	INCLUD.105
* 104	340-410E	STATOR ASS'Y 230V	1	INCLUD.105
* 104	340-410F	STATOR ASS'Y 240V	1	INCLUD.105
105	976-831	BRUSH TERMINAL	2	
106	958-422	TAPPING SCREW D5X65	2	
107	949-432	BOLT WASHER M6 (10 PCS.)	1	
108	307-735	SUPER LOCK WASHER	1	
109	307-743	MAGNET	1	
* 110	315-550	CONTROLLER	1	
* 110	315-709	CONTROLLER	1	FOR USA
111	305-812	TAPPING SCREW (W/FLANGE) D4X16 (BLACK)	2	
112	310-726	TAIL COVER	1	
113	304-035	TAPPING SCREW (W/FLANGE) D4X25 (BLACK)	2	
114	949-558	NUT M8 (10 PCS.)	2	
115	978-559	SUPER LOCK WASHER	2	
116	307-744	SPECIAL WASHER	1	
117	310-728	PULLEY (A)	1	
118	949-322	FLAT HD. SCREW M4X10 (10 PCS.)	4	
119	307-731	COVER	2	
120	310-743	INTERNAL WIRE (BLUE)	1	
* 121	315-551	INTERNAL WIRE (WHITE)	1	
* 121	310-744	INTERNAL WIRE (WHITE)	1	FOR USA
* 122	360-386	ARMATURE ASS'Y 100V-120V	1	INCLUD.124,125,127
* 122	360-462E	ARMATURE ASS'Y 230V-240V	1	INCLUD.124,125,127
123	976-441	BEARING LOCK	1	
124	620-1VV	BALL BEARING 6201VVCMP2L	2	
125	976-244	WASHER M12	1	
126	948-919	FEATHER KEY 4X4X15	2	
127	608-DDM	BALL BEARING 608DDC2PS2L	1	
128	995-096	MACHINE SCREW (W/WASHERS) M5X20 (BLACK)	4	
129	315-552	PULLEY COVER	1	
130	307-740	HANDLE	1	
131A	310-866	CAUTION LABEL (F)	1	
132	949-312	WING NUT M8 (10 PCS.)	1	
133	315-548	SIDE COVER (R)	1	
* 134	988-855	CORD ARMOR D8.8	1	
* 134	994-565	CORD ARMOR D10.1	1	
135	305-558	TAPPING SCREW (W/FLANGE) D5X25 (BLACK)	4	
136	949-429	BOLT WASHER M4 (10 PCS.)	2	
* 137	949-215	MACHINE SCREW M4X8 (10 PCS.)	2	
* 137	949-217	MACHINE SCREW M4X12 (10 PCS.)	2	FOR USA
138	934-028	CORD CLIP	1	
139	949-819	HEX. SOCKET HD. BOLT M5X10 (10 PCS.)	1	
140	310-720	GEAR CASE	1	

PARTS

C 12FSA

ITEM NO.	CODE NO.	DESCRIPTION	NO. USED	REMARKS
141	975-144	CABLE TIE	3	
142	996-281	HEX. SOCKET SET SCREW M8X16	1	
143	949-429	BOLT WASHER M4 (10 PCS.)	2	
144	949-217	MACHINE SCREW M4X12 (10 PCS.)	2	
145	310-725	COVER (A)	1	
146		NAME PLATE	1	
147	304-035	TAPPING SCREW (W/FLANGE) D4X25 (BLACK)	7	
* 148	988-894	TUBE (D)	2	
* 148	988-894	TUBE (D)	1	FOR USA
* 149	976-450	SWITCH (A) (2P PILLAR TYPE) W/O LOCK	1	
* 149	988-925	SWITCH (B) (1P PILLAR TYPE) W/LOCK	1	FOR USA
150	301-771	TAPPING SCREW (W/WASHERS) D4X12	1	
151	949-558	NUT M8 (10 PCS.)	2	
152	952-013	BOLT M8X100	1	
153	305-130	HINGE SHAFT	1	
154	301-760	WAVE WASHER	1	
155	310-898	SPRING	1	
156	305-128	SLEEVE	1	
157	310-727	BELT (200H13)	1	
158	949-433	BOLT WASHER M8 (10 PCS.)	1	
159	310-729	PULLEY (B)	1	
160	949-239	MACHINE SCREW M5X16 (10 PCS.)	2	
161	307-739	RETURN SPRING	1	
162	310-724	SAFETY COVER	1	
163	307-731	COVER	1	
164	949-322	FLAT HD. SCREW M4X10 (10 PCS.)	2	
165	307-732	STOPPER PIN	1	
166	988-821	LOCK SPRING	1	
167	310-721	SPINDLE ASS'Y	1	INCLUD.168-171
168	608-VVM	BALL BEARING 608VVC2PS2L	2	
169		PINION	1	
170	310-722	BEARING HOLDER	1	
171	600-3DD	BALL BEARING 6003DDCMPS2S	1	
* 172	315-549	SIDE COVER (L) ASS'Y	1	INCLUD.173-175
* 172	320-291	SIDE COVER (L) ASS'Y	1	INCLUD.173-175,200 FOR USA
173	310-184	GUIDE HOLDER	1	
174	305-812	TAPPING SCREW (W/FLANGE) D4X16 (BLACK)	1	
175	310-741	DUST GUIDE	1	
176	310-745	SPACER	1	
* 177	301-777	WASHER (A)	1	FOR NZL
* 177	301-778	WASHER (B)	1	FOR AUS,USA
* 178	976-819	COLLAR (B) FOR D25.4 HOLE	1	FOR AUS,USA
* 178	974-663Z	COLLAR (A) FOR D30 HOLE	1	FOR AUS
179	301-778	WASHER (B)	1	
180	976-811	BOLT (LEFT HAND) M8	1	
181		HITACHI LABEL	1	
182		CAUTION LABEL (G)	1	
* 183	949-397	WING BOLT M5X10 (10 PCS.)	1	FOR AUS,USA
* 184	949-429	BOLT WASHER M4 (10 PCS.)	1	FOR AUS,USA
* 185	310-148	SPINDLE COVER	1	FOR AUS,USA
* 186	998-980	SPACER	1	FOR AUS,USA

STANDARD ACCESSORIES

C 12FSA

ITEM NO.	CODE NO.	DESCRIPTION	NO. USED	REMARKS
701	972-043	WRENCH 10/13MM	1	
702A	985-051	BOX WRENCH 17MM	1	
703	998-845	DUST BAG	1	

OPTIONAL ACCESSORIES

ITEM NO.	CODE NO.	DESCRIPTION	NO. USED	REMARKS
901	305-546	TCT SAW BLADE 305MM-D25.4 HOLE-NT60	1	
902	309-418	TCT SAW BLADE 305MM-D25.4 HOLE-NT80	1	
903A	301-721	TCT SAW BLADE 305MM-D25.4 HOLE-NT90	1	
904A	310-875	TCT SAW BLADE 305MM-D25.4 HOLE-NT96	1	
905	305-174	WISE (A) ASS'Y	1	INCLUD.905-923
906	305-175	WISE HOLDER	1	
907	305-184	SCREW HOLDER	1	
908	305-176	HOLDER PLATE	1	
909	305-177	SLEEVE (A)	1	
910	305-178	CLAMP BOLT M10	1	
911	996-219	CLAMP LEVER	1	
912	305-179	CLUTCH SPRING	1	
913	305-180	CLUTCH SCREW	1	
914	305-181	SCREW	1	
915	996-263	KNOB	1	
916	949-548	ROLL PIN D4X25 (10 PCS.)	1	
917	949-434	BOLT WASHER M10 (10 PCS.)	1	
918	305-182	WISE (A)	1	
919	997-314	MACHINE SCREW (W/WASHERS) M6X10	2	
920	998-832	LABEL (A)	1	
921	996-246	WASHER (C)	1	
922	305-183	SHAFT (B)	1	
923	305-419	KNOB BOLT M6X51	1	
* 924	320-277	GUIDE ASS'Y	1	INCLUD.925-928 FOR USA
* 925	303-397	HOLDER	2	FOR USA
* 926	303-757	STOPPER	1	FOR USA
* 927	998-836	KNOB BOLT M6X11	1	FOR USA
* 928	302-503	KNOB BOLT M6X22	2	FOR USA